



US 20250198837A1

(19) **United States**

(12) **Patent Application Publication**  
**GERSTEN et al.**

(10) **Pub. No.: US 2025/0198837 A1**

(43) **Pub. Date: Jun. 19, 2025**

(54) **LIGHT SENSING LOW ENERGY WIRELESS TAG**

(52) **U.S. Cl.**  
CPC ..... **G01J 1/44** (2013.01); **H02J 50/001** (2020.01)

(71) Applicant: **Wiliot, Ltd.**, Caesarea (IL)

(72) Inventors: **Eylon GERSTEN**, Even Yehuda (IL);  
**Alon YEHEZKELY**, Haifa (IL)

(57) **ABSTRACT**

(73) Assignee: **Wiliot, Ltd.**, Caesarea (IL)

(21) Appl. No.: **18/540,191**

(22) Filed: **Dec. 14, 2023**

**Publication Classification**

(51) **Int. Cl.**  
**G01J 1/44** (2006.01)  
**H02J 50/00** (2016.01)

A wireless Internet of Things (IoT) device for detecting light exposure is provided. The IoT device includes a light sensor having an organic active layer that detects an intensity of light; an integrated circuit (IC), wherein the integrated circuit includes an oscillating circuit that is coupled to the light sensor to output a frequency value for the detected intensity of light; and at least one harvesting antenna that harvests an ambient radio frequency (RF).

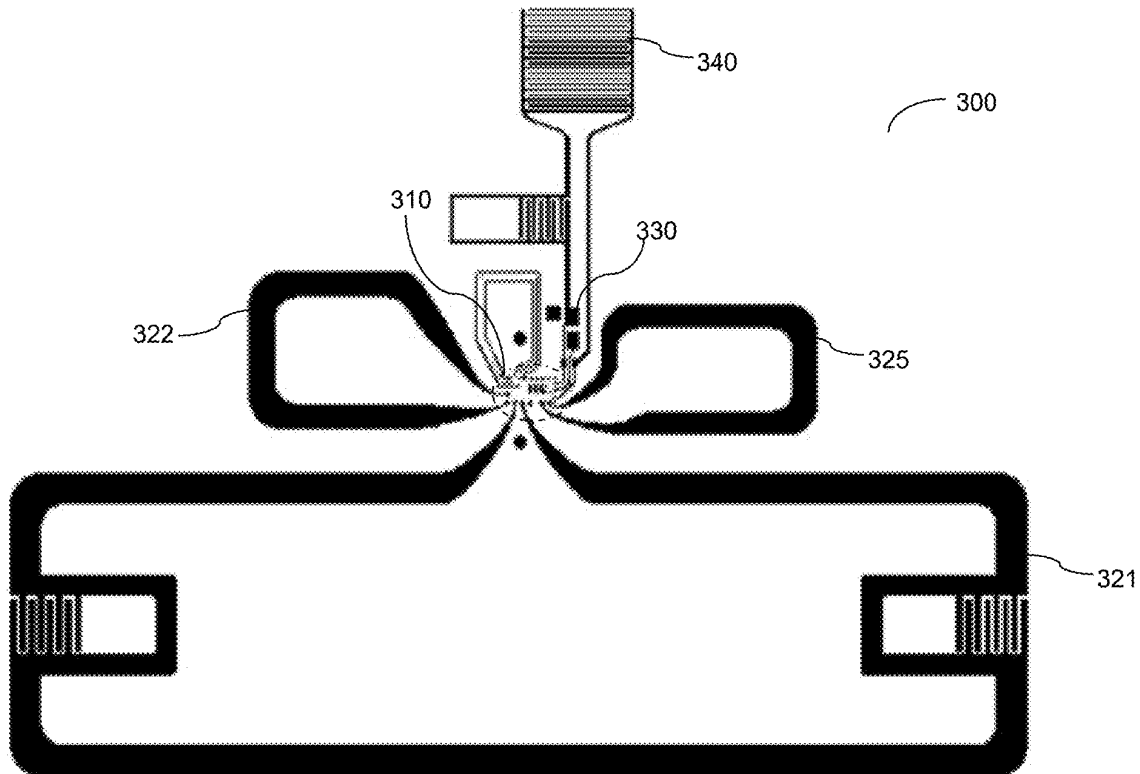



(19) **United States**

(12) **Patent Application Publication** (10) **Pub. No.: US 2025/0199572 A1**

**LEE et al.**

(43) **Pub. Date: Jun. 19, 2025**

(54) **FOLDABLE ELECTRONIC DEVICE INCLUDING SEGMENTED ANTENNA**

(52) **U.S. Cl.**  
CPC ..... **G06F 1/1618** (2013.01); **G06F 1/1626** (2013.01); **H01Q 1/2291** (2013.01); **H01Q 21/28** (2013.01)

(71) Applicant: **Samsung Electronics Co., Ltd.**, Suwon-si (KR)

(72) Inventors: **Bomi LEE**, Suwon-si (KR); **Junhee HAN**, Suwon-si (KR); **Jeongseob KIM**, Suwon-si (KR)

(57) **ABSTRACT**

An electronic device is provided. The electronic device includes a first housing including a sidewall that includes conductive portions spaced apart from each other and non-conductive portions disposed between the conductive portions, a second housing including a conductive sidewall having a length substantially equal to a length of the sidewall, a hinge structure rotatably connecting the first housing and the second housing, a ground portion disposed within the second housing, memory storing one or more computer programs, and one or more processors disposed within the first housing and being electrically connected to at least one of the conductive portions operating as a radiator of an antenna for communicating with an external electronic device, wherein the one or more computer programs include computer-executable instructions that, when executed by the one or more processors individually or collectively, cause the electronic device to electrically disconnect the conductive side wall from the grounding portion within the second housing when the electronic device is in a folded state in which a first surface of the first housing and a second surface of the second housing face different directions, and electrically connect the conductive side wall to the grounding portion within the second housing when the electronic device is in an unfolded state in which a direction faced by the first surface and a direction faced by the second surface are a same direction.

(21) Appl. No.: **19/054,213**

(22) Filed: **Feb. 14, 2025**

**Related U.S. Application Data**

(63) Continuation of application No. PCT/KR2023/008634, filed on Jun. 21, 2023.

(30) **Foreign Application Priority Data**

Aug. 19, 2022 (KR) ..... 10-2022-0104190  
Sep. 2, 2022 (KR) ..... 10-2022-0111744

**Publication Classification**

(51) **Int. Cl.**  
**G06F 1/16** (2006.01)  
**H01Q 1/22** (2006.01)  
**H01Q 21/28** (2006.01)

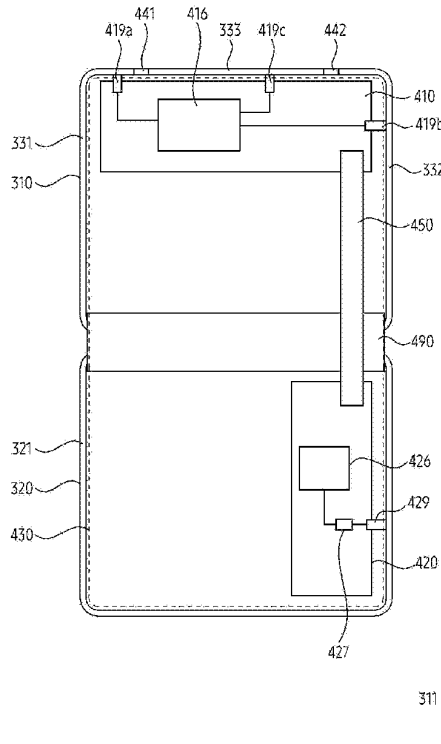



US 20250200319A1

(19) **United States**

(12) **Patent Application Publication**  
**Feldhofer et al.**

(10) **Pub. No.: US 2025/0200319 A1**

(43) **Pub. Date: Jun. 19, 2025**

(54) **RF COMMUNICATIONS DEVICE WITH EMI REDUCTION**

(52) **U.S. Cl.**  
CPC ..... **G06K 19/0715** (2013.01); **G06K 19/0723** (2013.01)

(71) Applicant: **NXP B.V.**, Eindhoven (NL)

(57) **ABSTRACT**

(72) Inventors: **Martin Feldhofer**, Weiz (AT); **Björn Rasmussen**, Graz (AT); **Peter Thüringer**, Graz (AT)

A Radio Frequency (RF) communications device includes a pair of antenna terminals, which are connectable to an antenna. The device also includes an automatic gain controller, which is coupled to the antenna terminals for receiving an output current of the antenna. The automatic gain controller is operable to convert the output current of the antenna into a modulated current. The device further includes a rectifier, which is coupled to the automatic gain controller to receive the modulated current. The rectifier is operable to convert the modulated current into a rectified current. The device also includes a voltage limiter, which is coupled to the rectifier for receiving the rectified current. The voltage limiter is operable to convert the rectified current into a limited rectified voltage for supplying power to the RF communications device. An RF identification (RFID) tag comprising the RF communications device is also disclosed.

(21) Appl. No.: **18/955,377**

(22) Filed: **Nov. 21, 2024**

(30) **Foreign Application Priority Data**

Dec. 14, 2023 (EP) ..... 23216838.5

**Publication Classification**

(51) **Int. Cl.**  
**G06K 19/07** (2006.01)

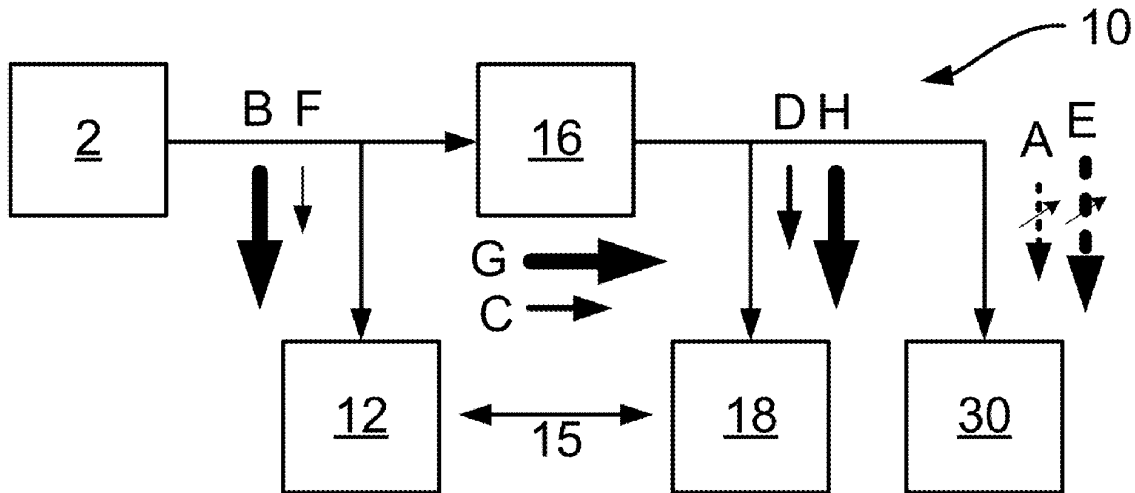



US 20250202094A1

(19) **United States**

(12) **Patent Application Publication**  
**HUANG et al.**

(10) **Pub. No.: US 2025/0202094 A1**

(43) **Pub. Date: Jun. 19, 2025**

(54) **FIXING MEMBER, ANTENNA SYSTEM, AND ELECTRONIC DEVICE**

**Publication Classification**

(71) Applicant: **Beijing Zitiao Network Technology Co., Ltd.**, Beijing (CN)

(51) **Int. Cl.**  
**H01Q 1/22** (2006.01)  
**H01Q 13/10** (2006.01)

(72) Inventors: **Lishan HUANG**, Beijing (CN);  
**Guanghai LIU**, Beijing (CN); **Jiu XIA**,  
Beijing (CN)

(52) **U.S. Cl.**  
CPC ..... **H01Q 1/22** (2013.01); **H01Q 13/10**  
(2013.01)

(21) Appl. No.: **18/849,320**

(57) **ABSTRACT**

(22) PCT Filed: **Feb. 23, 2023**

(86) PCT No.: **PCT/CN2023/077957**

§ 371 (c)(1),  
(2) Date: **Sep. 20, 2024**

The present disclosure relates to a fixing member, an antenna system, and an electronic device. A cross section of the fixing member (10) is annular, and a side wall of the fixing member (10) includes at least one first area (A); at least one first radiation slot (101) is arranged in the first area (A), and an extension direction of the first radiation slot (101) is consistent with a rotation direction of the fixing member (10); and the fixing member (10) is electrically connectable with a feed source to radiate wireless signals.

(30) **Foreign Application Priority Data**

Mar. 22, 2022 (CN) ..... 202210286524.6

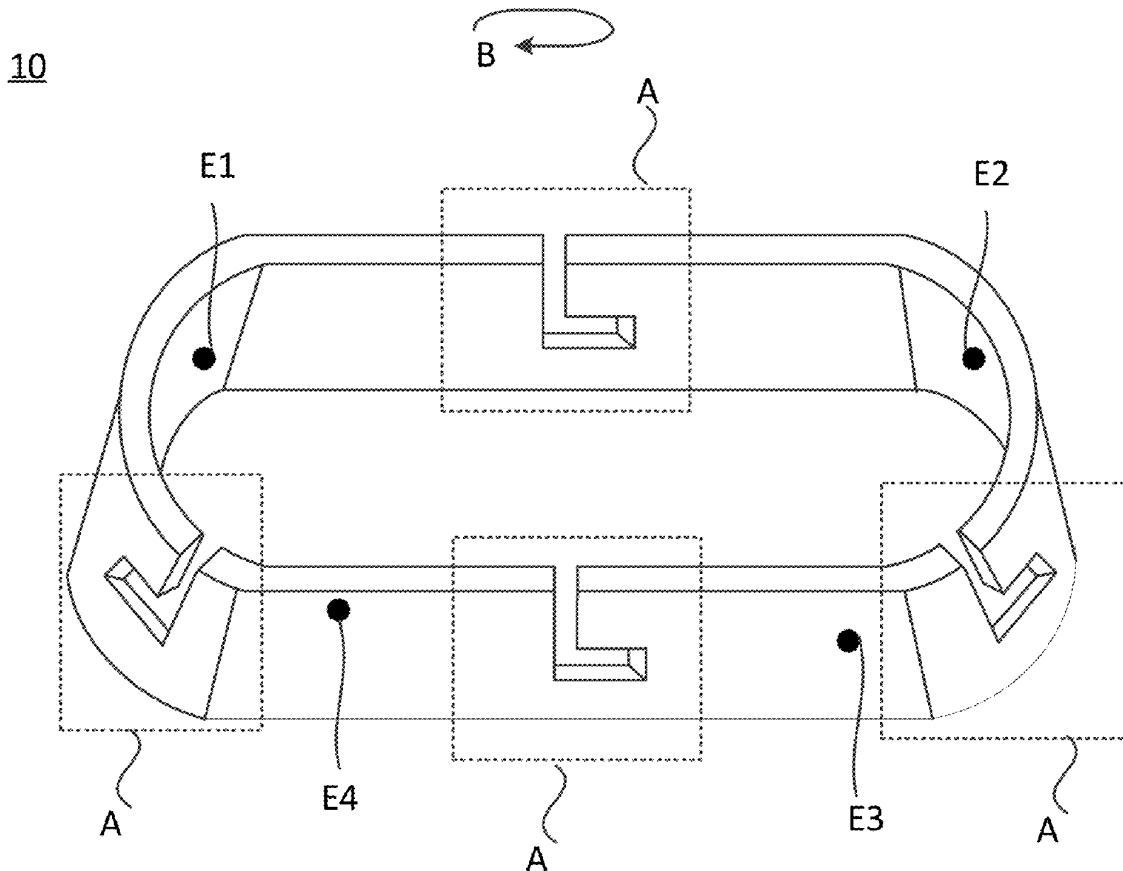



US 20250202095A1

(19) **United States**

(12) **Patent Application Publication**  
Hu et al.

(10) **Pub. No.: US 2025/0202095 A1**

(43) **Pub. Date: Jun. 19, 2025**

(54) **FOLDABLE ELECTRONIC DEVICE INCLUDING ANTENNA**

**Publication Classification**

(71) Applicant: **Honor Device Co., Ltd.**, Shenzhen (CN)

(51) **Int. Cl.**  
**H01Q 1/22** (2006.01)  
**H01Q 13/10** (2006.01)

(72) Inventors: **Yiwu Hu**, Shenzhen (CN); **Aofang Zhang**, Shenzhen (CN); **Kunpeng Wei**, Shenzhen (CN); **Qiao Guan**, Shenzhen (CN)

(52) **U.S. Cl.**  
CPC ..... **H01Q 1/2266** (2013.01); **H01Q 13/10** (2013.01)

(21) Appl. No.: **18/840,741**

(57) **ABSTRACT**

(22) PCT Filed: **May 6, 2023**

Embodiments of this application provide a foldable electronic device including an antenna. The foldable electronic device include a first body, a second body, and a rotating shaft connected to the first body and the second body. The first body and the second body are rotatable around the rotating shaft. As the first body and the second body rotate, a form of the foldable electronic device may be switched between a folded state and an unfolded state. The antenna may be a slot antenna formed by hollowing out a metal housing of the first body or a metal housing of the second body. The slot antenna may include a first branch and a second branch, where the first branch and the second branch may be perpendicular to each other. This can reduce the antenna directivity coefficient, improve an antenna radiation pattern, and improve a signal coverage capability of the electronic device.

(86) PCT No.: **PCT/CN2023/092410**

§ 371 (c)(1),

(2) Date: **Aug. 22, 2024**

(30) **Foreign Application Priority Data**

Aug. 3, 2022 (CN) ..... 202210926607.7

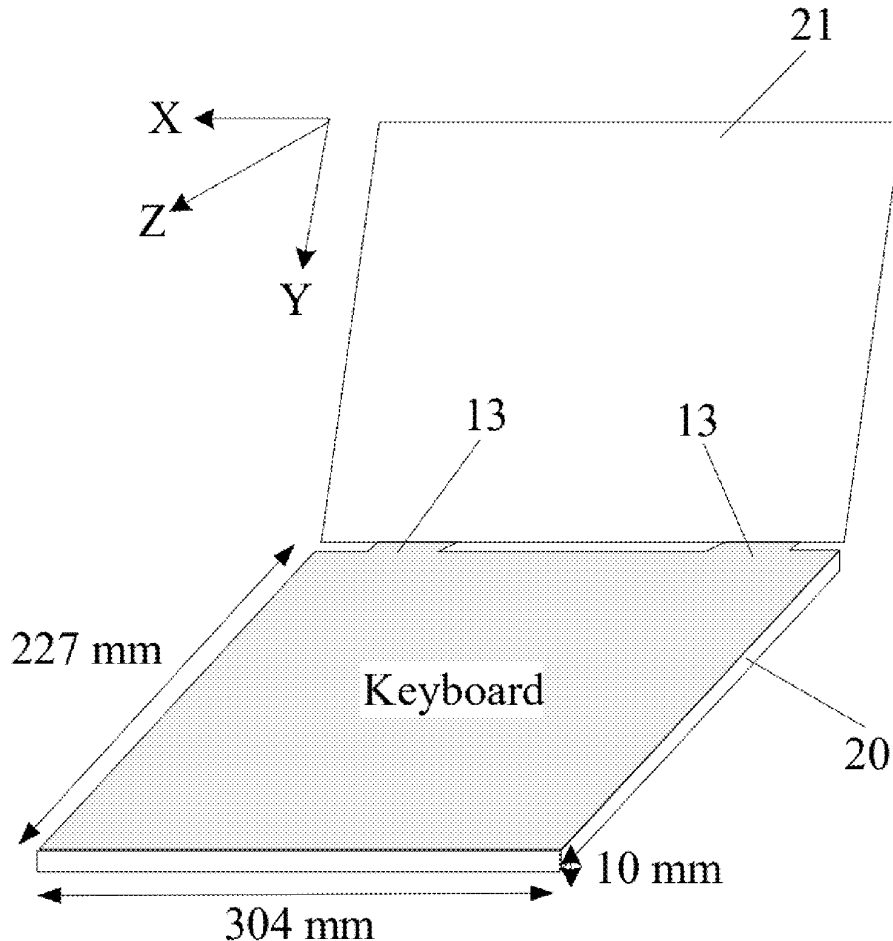



US 20250202107A1

(19) **United States**

(12) **Patent Application Publication**  
**ZOU et al.**

(10) **Pub. No.: US 2025/0202107 A1**

(43) **Pub. Date: Jun. 19, 2025**

(54) **ANTENNA AND COMMUNICATION DEVICE**

*H01Q 9/04* (2006.01)

*H01Q 19/10* (2006.01)

(71) Applicant: **HUAWEI TECHNOLOGIES CO., LTD.**, Shenzhen (CN)

(52) **U.S. Cl.**

CPC ..... *H01Q 3/32* (2013.01); *H01Q 1/246*

(2013.01); *H01Q 9/0485* (2013.01); *H01Q*

*19/10* (2013.01)

(72) Inventors: **Meng ZOU**, Shanghai (CN); **Ke LONG**, Shanghai (CN)

(21) Appl. No.: **19/071,959**

(57)

**ABSTRACT**

(22) Filed: **Mar. 6, 2025**

This application relates to an antenna and a communication device. An example antenna includes a reflector, a resonator, a radiator, and an enclosure frame. The resonator is disposed on a side of the reflector and is configured to filter a signal of the antenna. The radiator is disposed on a side of the resonator facing away from the reflector, and the radiator and the resonator are electrically connected. The enclosure frame is disposed on the same side on the reflector as the resonator, and forms, with the reflector, an accommodating space for accommodating the resonator and the radiator. The enclosure frame has a metal surface.

**Related U.S. Application Data**

(63) Continuation of application No. PCT/CN2022/117393, filed on Sep. 6, 2022.

**Publication Classification**

(51) **Int. Cl.**

*H01Q 3/32* (2006.01)

*H01Q 1/24* (2006.01)

**12**

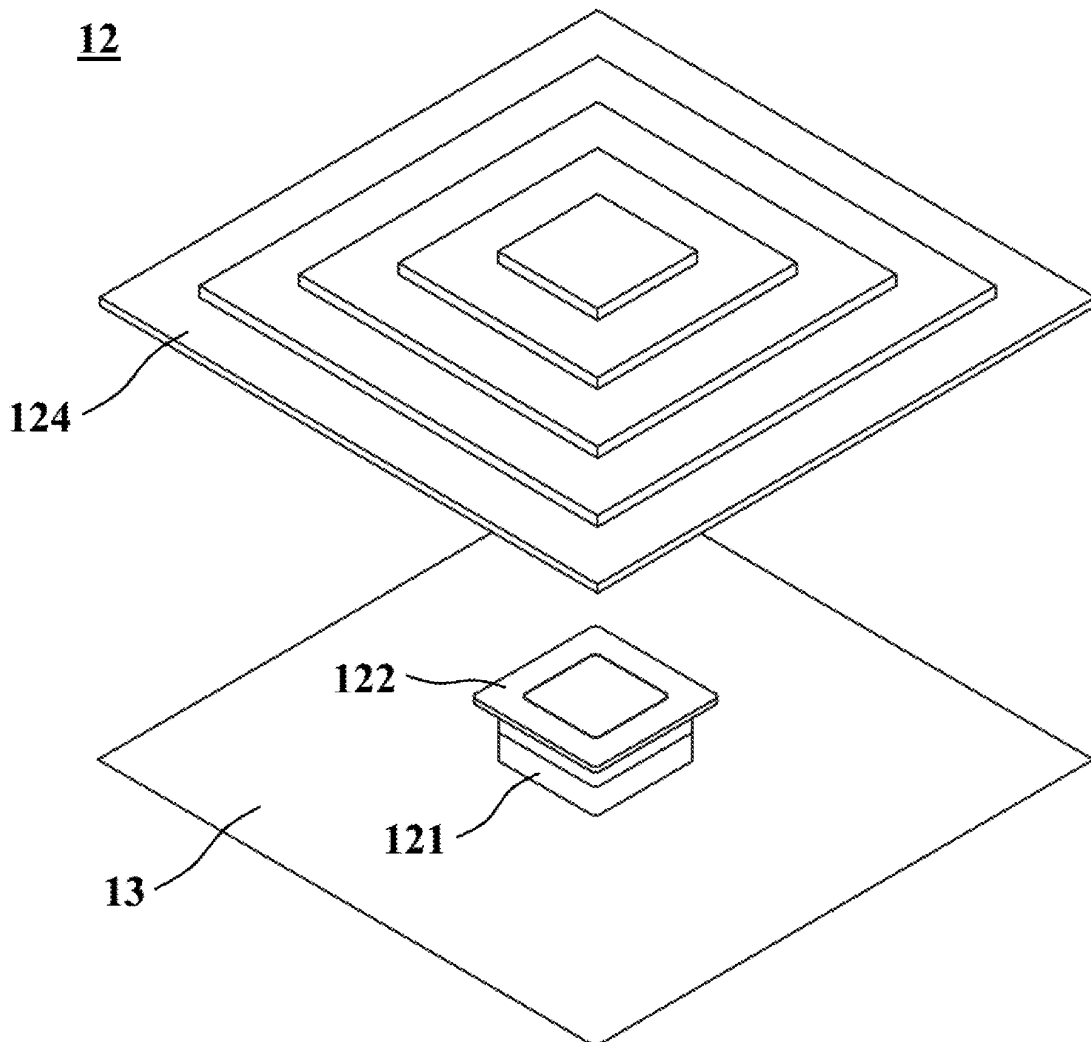



US 20250202114A1

(19) **United States**

(12) **Patent Application Publication**  
**QIN**

(10) **Pub. No.: US 2025/0202114 A1**

(43) **Pub. Date: Jun. 19, 2025**

(54) **ELECTRONIC DEVICE**

**Publication Classification**

(71) Applicant: **VIVO MOBILE COMMUNICATION CO., LTD.**, Guangdong (CN)

(72) Inventor: **Yue QIN**, Guangdong (CN)

(73) Assignee: **VIVO MOBILE COMMUNICATION CO., LTD.**, Guangdong (CN)

(21) Appl. No.: **19/069,833**

(22) Filed: **Mar. 4, 2025**

**Related U.S. Application Data**

(63) Continuation of application No. PCT/CN2023/115624, filed on Aug. 30, 2023.

**Foreign Application Priority Data**

Sep. 5, 2022 (CN) ..... 202211079301.9

(51) **Int. Cl.**  
**H01Q 5/35** (2015.01)  
**H01Q 1/52** (2006.01)  
**H01Q 7/00** (2006.01)  
**H01Q 9/04** (2006.01)

(52) **U.S. Cl.**  
CPC ..... **H01Q 5/35** (2015.01); **H01Q 1/521** (2013.01); **H01Q 7/00** (2013.01); **H01Q 9/0407** (2013.01)

(57) **ABSTRACT**

This application discloses an electronic device, including an antenna cluster, where the antenna cluster includes at least two antennas arranged in sequence, each antenna corresponds to a feed point, the feed point is electrically connected to a feed structure, any two adjacent antennas of the at least two antennas are at least partially arranged in sleeving mode, and any two adjacent antennas of the at least two antennas are spaced apart.

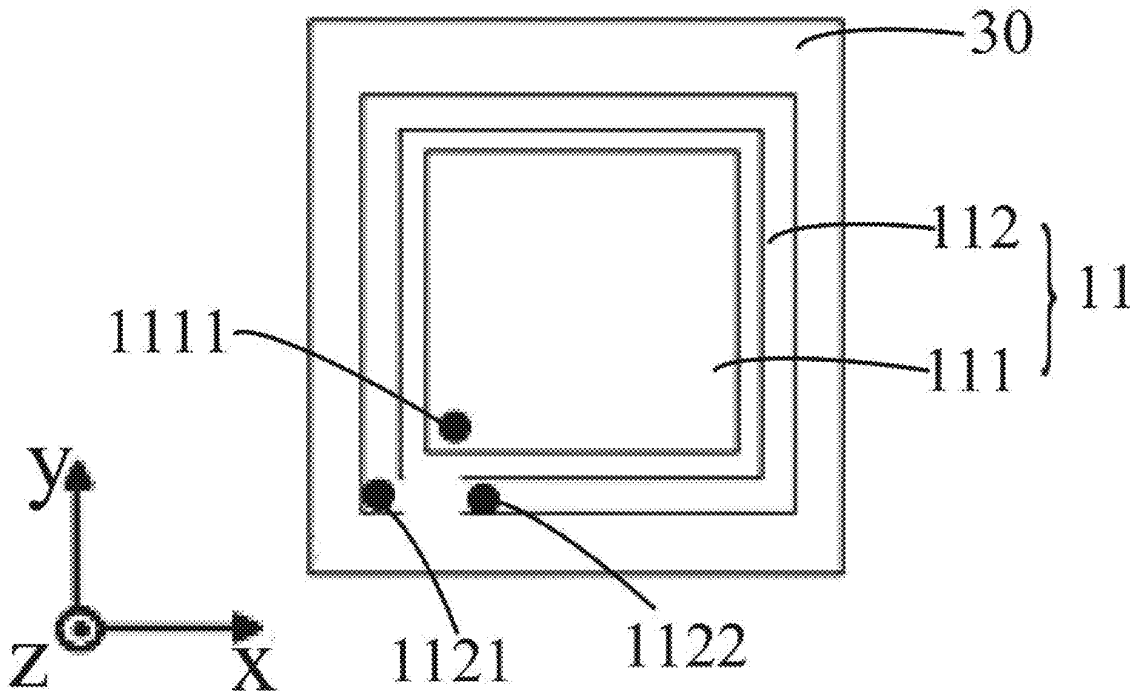



US 20250202116A1

(19) **United States**

(12) **Patent Application Publication**  
**SONG**

(10) **Pub. No.: US 2025/0202116 A1**

(43) **Pub. Date: Jun. 19, 2025**

(54) **ANTENNA STRUCTURE AND ELECTRONIC DEVICE**

**Publication Classification**

(71) Applicant: **VIVO MOBILE COMMUNICATION CO., LTD.**, Dongguan (CN)

(51) **Int. Cl.**  
*H01Q 5/50* (2015.01)  
*H01Q 1/24* (2006.01)  
*H01Q 5/378* (2015.01)

(72) Inventor: **Bo SONG**, Dongguan (CN)

(52) **U.S. Cl.**  
CPC ..... *H01Q 5/50* (2015.01); *H01Q 5/378* (2015.01); *H01Q 1/243* (2013.01)

(73) Assignee: **VIVO MOBILE COMMUNICATION CO., LTD.**, Dongguan (CN)

(57) **ABSTRACT**

(21) Appl. No.: **19/070,471**

This application discloses an antenna structure and an electronic device. The antenna structure includes an antenna radiation body, a first coupled radiation branch, a second coupled radiation branch, a first feed, a first matching circuit, and a second matching circuit. The antenna radiation body is located between the first coupled radiation branch and the second coupled radiation branch, there is a gap between the antenna radiation body and the first coupled radiation branch, and there is a gap between the antenna radiation body and the second coupled radiation branch. The first feed is disposed between a first feed point on the antenna radiation body and a ground plane. The first matching circuit is disposed between a first position of the antenna radiation body and a ground plane. The second matching circuit is disposed between a second position of the antenna radiation body and a ground plane.

(22) Filed: **Mar. 4, 2025**

**Related U.S. Application Data**

(63) Continuation of application No. PCT/CN2023/115625, filed on Aug. 30, 2023.

(30) **Foreign Application Priority Data**

Sep. 5, 2022 (CN) ..... 202211078696.0

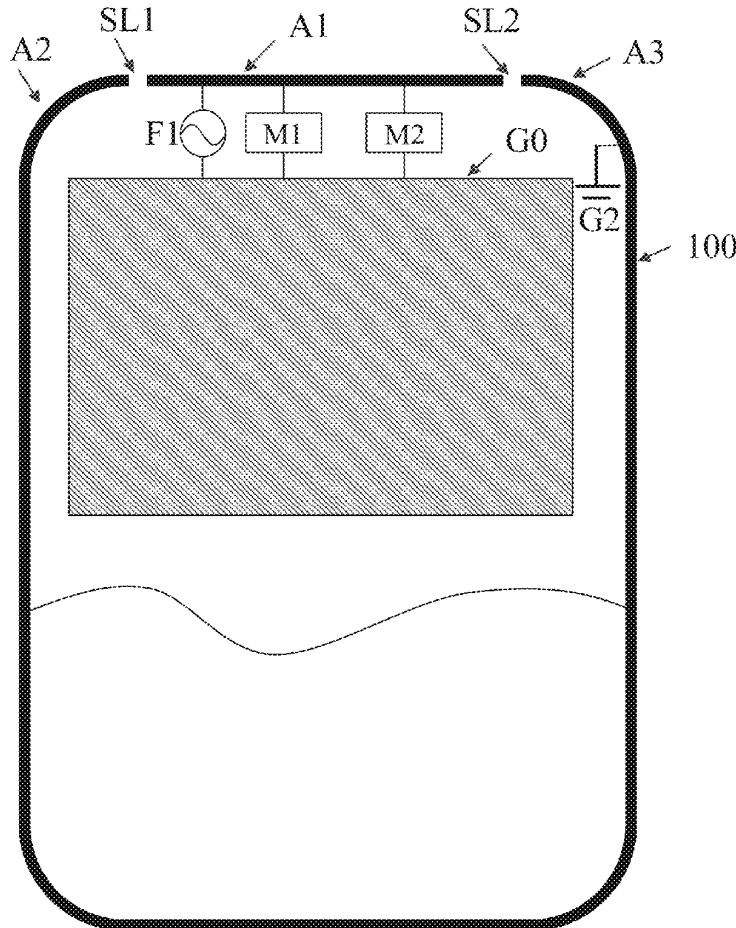



(19) **United States**

(12) **Patent Application Publication**  
**TAI et al.**

(10) **Pub. No.: US 2025/0202122 A1**

(43) **Pub. Date: Jun. 19, 2025**

(54) **ANTENNA STRUCTURE**

*H01Q 1/50* (2006.01)

*H01Q 5/307* (2015.01)

(71) Applicant: **Wistron NeWeb Corp.**, Hsinchu (TW)

(52) **U.S. Cl.**

(72) Inventors: **Chih-Feng TAI**, Hsinchu (TW);  
**Kuei-Cheng WANG**, Hsinchu (TW);  
**De-Shao YAO**, Hsinchu (TW)

CPC ..... *H01Q 13/10* (2013.01); *H01Q 1/38*  
(2013.01); *H01Q 1/50* (2013.01); *H01Q 5/307*  
(2015.01)

(21) Appl. No.: **18/954,851**

(57) **ABSTRACT**

(22) Filed: **Nov. 21, 2024**

An antenna structure includes a metal mechanism element, a ground element, a first radiation element, a second radiation element, and a dielectric substrate. The metal mechanism element has a slot. The ground element is coupled to the metal mechanism element. The first radiation element is coupled to a feeding point. The first radiation element is also coupled to a grounding point on the ground element. The second radiation element is coupled to the feeding point. The second radiation element is adjacent to the first radiation element. The dielectric substrate is adjacent to the slot of the metal mechanism element. The ground element, the first radiation element, and the second radiation element are disposed on the dielectric substrate.

(30) **Foreign Application Priority Data**

Dec. 15, 2023 (TW) ..... 112149040

**Publication Classification**

(51) **Int. Cl.**  
*H01Q 13/10* (2006.01)  
*H01Q 1/38* (2006.01)

100

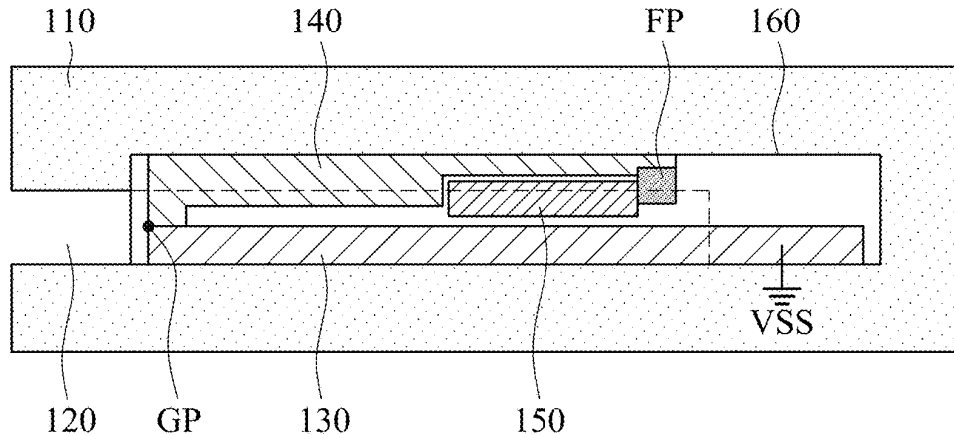



US 20250202123A1

(19) **United States**

(12) **Patent Application Publication**  
**WANG et al.**

(10) **Pub. No.: US 2025/0202123 A1**

(43) **Pub. Date: Jun. 19, 2025**

(54) **ANTENNA MODULE AND ELECTRONIC DEVICE**

(71) Applicant: **Lenovo (Beijing) Limited**, Beijing (CN)

(72) Inventors: **Wenlei WANG**, Beijing (CN); **Dafei MO**, Beijing (CN)

(21) Appl. No.: **18/983,167**

(22) Filed: **Dec. 16, 2024**

(30) **Foreign Application Priority Data**

Dec. 19, 2023 (CN) ..... 202311753367.6

**Publication Classification**

(51) **Int. Cl.**  
**H01Q 13/10** (2006.01)

(52) **U.S. Cl.**  
CPC ..... **H01Q 13/10** (2013.01)

(57) **ABSTRACT**

An antenna module includes a slot antenna structure and a metamaterial module. The slot antenna structure includes a feed point and a first substrate. The feed point is arranged at the first substrate. The metamaterial module is arranged at the first substrate. A position of the metamaterial module does not overlap with a position of the feed point. The metamaterial module is coupled with the feed point. The metamaterial module is configured to disperse an electromagnetic wave of the feed point.

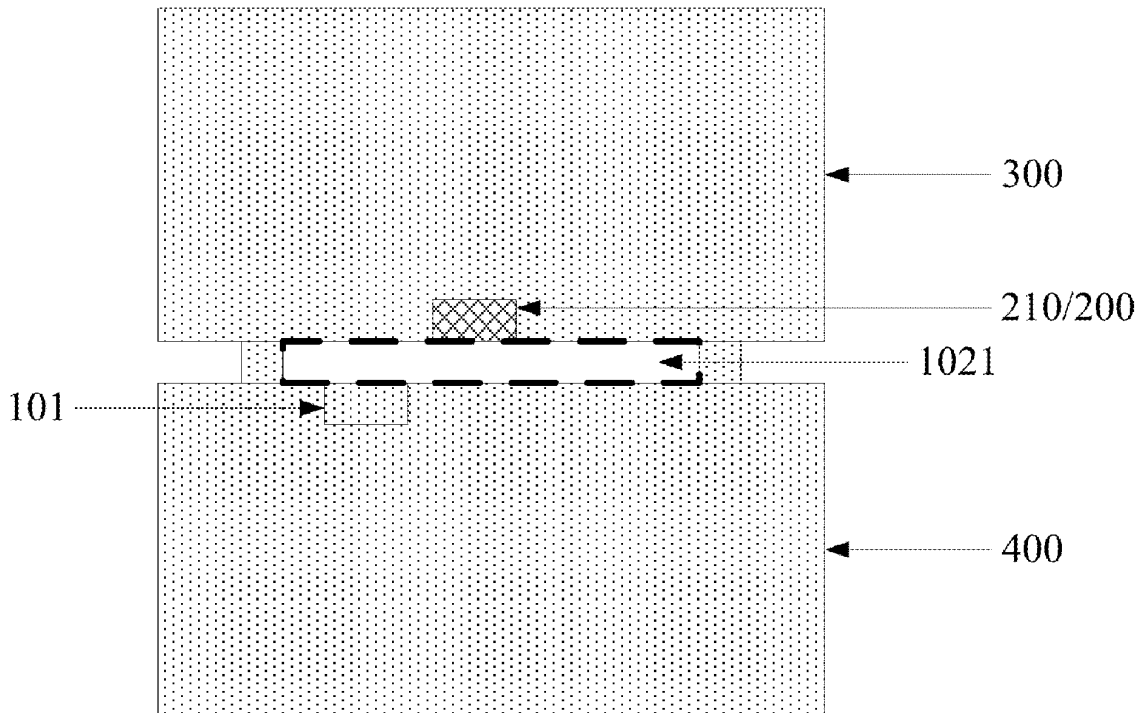



US 20250202131A1

(19) **United States**

(12) **Patent Application Publication**  
**ZARRIN RAFIE et al.**

(10) **Pub. No.: US 2025/0202131 A1**

(43) **Pub. Date: Jun. 19, 2025**

(54) **INTEGRATED ANTENNA ARRAY WITH  
FEED AND CALIBRATION NETWORKS**

(71) Applicant: **Syntronic Research and Development  
Canada Inc., Kanata (CA)**

(72) Inventors: **Babak ZARRIN RAFIE, Ottawa (CA);  
Elham BALADI, Kanata (CA);  
Behnam GOHARFAR, Kanata (CA)**

(73) Assignee: **Syntronic Research and Development  
Canada Inc., Kanata (CA)**

(21) Appl. No.: **18/980,025**

(22) Filed: **Dec. 13, 2024**

**Related U.S. Application Data**

(60) Provisional application No. 63/610,453, filed on Dec. 15, 2023.

**Publication Classification**

(51) **Int. Cl.**  
**H01Q 21/06** (2006.01)  
**H04B 17/12** (2015.01)  
**H04B 17/21** (2015.01)

(52) **U.S. Cl.**  
CPC ..... **H01Q 21/06** (2013.01); **H04B 17/12**  
(2015.01); **H04B 17/221** (2023.05)

(57) **ABSTRACT**

The present disclosure provides an integrated antenna array with feed and calibration networks. These components are integrated together on a multi-layer printed circuit board (PCB). This integration on the PCB allows the array to be smaller, more cost-effective while achieving the required array performance for 5G NR FR1 mMIMO radios and supporting both single and multi-beam applications. The antenna array utilizes electrically small antennas with high-permittivity dielectrics to minimize both size and mutual coupling effects.

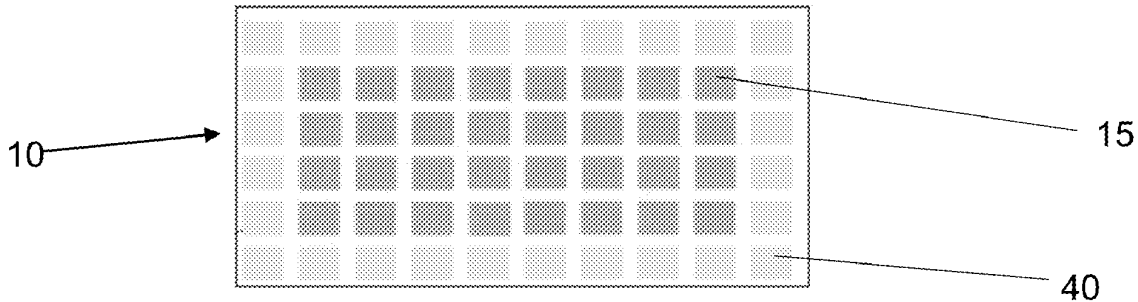



US 20250202134A1

(19) **United States**

(12) **Patent Application Publication**  
**QIANG et al.**

(10) **Pub. No.: US 2025/0202134 A1**

(43) **Pub. Date: Jun. 19, 2025**

(54) **ANTENNA DEVICE**

**Publication Classification**

(71) Applicant: **TOHOKU UNIVERSITY**, Sendai-shi, Miyagi (JP)

(51) **Int. Cl.**  
*H01Q 25/00* (2006.01)  
*H01Q 19/24* (2006.01)  
*H01Q 21/20* (2006.01)

(72) Inventors: **Chen QIANG**, Sendai-shi (JP); **Junyi XU**, Sendai-shi (JP)

(52) **U.S. Cl.**  
CPC ..... *H01Q 25/001* (2013.01); *H01Q 19/24* (2013.01); *H01Q 21/205* (2013.01)

(73) Assignee: **TOHOKU UNIVERSITY**, Sendai-shi, Miyagi (JP)

(21) Appl. No.: **18/847,375**

(57) **ABSTRACT**

(22) PCT Filed: **Dec. 26, 2022**

(86) PCT No.: **PCT/JP2022/047865**

§ 371 (c)(1),

(2) Date: **Sep. 16, 2024**

(30) **Foreign Application Priority Data**

Mar. 18, 2022 (WO) ..... PCT/JP2022/012896

A ground component is made of a columnar or cylindrical conductor and is connected to a ground potential. A cover component is cylindrical and made of a material containing dielectrics. The cover component is arranged at a distance from the ground component so as to cover the outer surface of the ground component, with the ground component inserted therein. The antenna element is arranged between the inner surface of the cover component and the outer surface of the ground component.

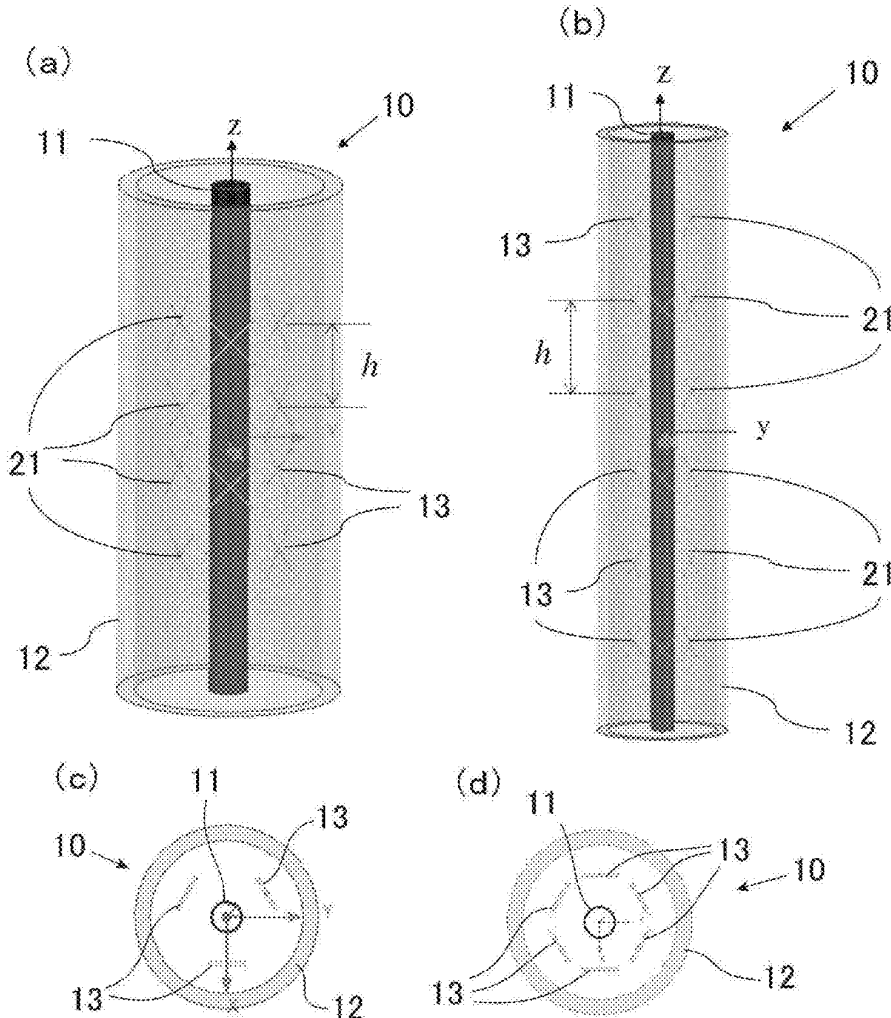



US 20250202509A1

(19) **United States**

(12) **Patent Application Publication**  
**MORI et al.**

(10) **Pub. No.: US 2025/0202509 A1**

(43) **Pub. Date: Jun. 19, 2025**

(54) **RADIO FREQUENCY CIRCUIT**

**Publication Classification**

(71) Applicant: **Murata Manufacturing Co., Ltd.**,  
Nagaokakyo-shi (JP)

(51) **Int. Cl.**  
**H04B 1/00** (2006.01)  
**H04B 1/04** (2006.01)

(72) Inventors: **Hirotsugu MORI**, Nagaokakyo-shi (JP); **Morio TAKEUCHI**,  
Nagaokakyo-shi (JP)

(52) **U.S. Cl.**  
CPC ..... **H04B 1/0078** (2013.01); **H04B 1/04**  
(2013.01); **H04B 2001/0416** (2013.01)

(73) Assignee: **Murata Manufacturing Co., Ltd.**,  
Nagaokakyo-shi (JP)

(57) **ABSTRACT**

(21) Appl. No.: **19/058,052**

(22) Filed: **Feb. 20, 2025**

**Related U.S. Application Data**

(63) Continuation of application No. PCT/JP2023/020382, filed on May 31, 2023.

**Foreign Application Priority Data**

Aug. 23, 2022 (JP) ..... 2022-132852

A radio frequency circuit includes: a first filter having a passband that includes a transmission band of a first band to which power classes are applicable; a second filter having a passband that includes the transmission band of the first band; a first combiner that includes a first input terminal, a second input terminal, and an output terminal; and a first switch that includes a first terminal, a second terminal, a third terminal, a fourth terminal, and a fifth terminal. The output terminal of the first combiner is connected to an antenna connection terminal.

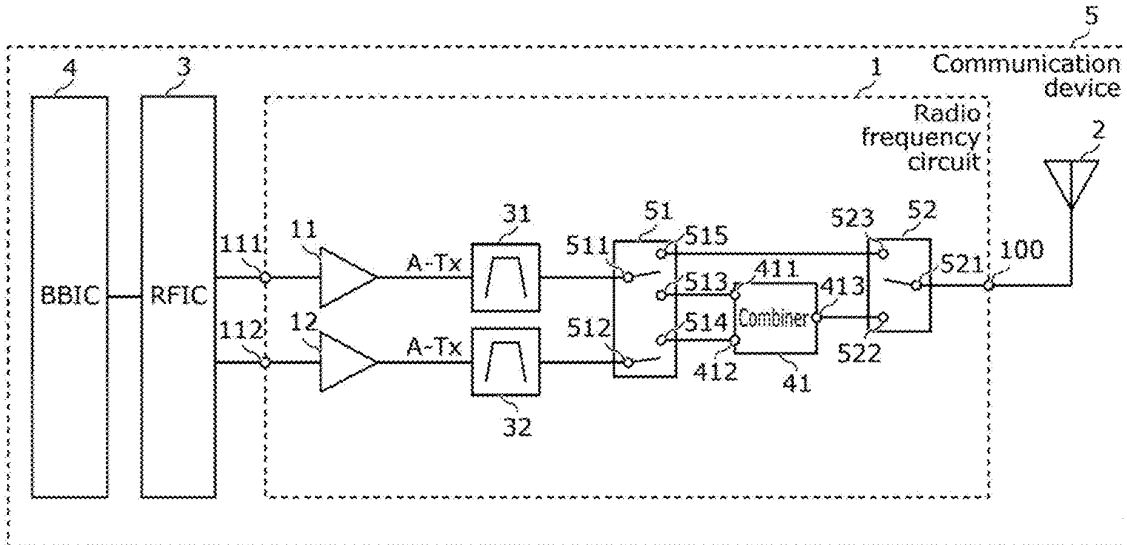



(19) **United States**

(12) **Patent Application Publication**  
**KIM et al.**

(10) **Pub. No.: US 2025/0202514 A1**

(43) **Pub. Date: Jun. 19, 2025**

(54) **ELECTRONIC DEVICE AND METHOD FOR CONTROLLING GROUND CIRCUIT**

**Publication Classification**

(71) Applicant: **Samsung Electronics Co., Ltd.**,  
Suwon-si (KR)

(51) **Int. Cl.**  
**H04B 1/10** (2006.01)

(52) **U.S. Cl.**  
CPC ..... **H04B 1/1027** (2013.01)

(72) Inventors: **Gibae KIM**, Suwon-si (KR); **Kangho KO**, Suwon-si (KR); **Kumjong SUN**, Suwon-si (KR); **Younggung SONG**, Suwon-si (KR); **Gunhyuk YOON**, Suwon-si (KR); **Sunggeun LEE**, Suwon-si (KR); **Yonggoo LEE**, Suwon-si (KR); **Donghyun JO**, Suwon-si (KR)

(57) **ABSTRACT**

An electronic device is provided. The electronic device includes an audio module, an audio module ground circuit for the audio module, at least one antenna, at least one antenna ground circuit for the at least one antenna memory storing one or more computer programs, and one or more processors communicatively coupled to the audio module, the audio module ground circuit, the least one antenna, the least one antenna ground circuit and the memory, and wherein the one or more computer programs include computer-executable instructions that, when executed by the at least one or more processors individually or collectively, cause the electronic device to identify that the electronic device is in time division multiple access (TDMA) communication or time division duplex (TDD) communication while the audio module operates, identify a transmission power in the communication based on identifying that the electronic device is in the TDMA communication or the TDD communication while the audio module operates, and change a ground circuit of the audio module from the audio module ground circuit to one of the at least one antenna ground circuit in a case that the identified transmission power exceeds a threshold.

(21) Appl. No.: **19/066,940**

(22) Filed: **Feb. 28, 2025**

**Related U.S. Application Data**

(63) Continuation of application No. PCT/KR2023/012738, filed on Aug. 28, 2023.

(30) **Foreign Application Priority Data**

Sep. 2, 2022 (KR) ..... 10-2022-0111748  
Sep. 29, 2022 (KR) ..... 10-2022-0124733

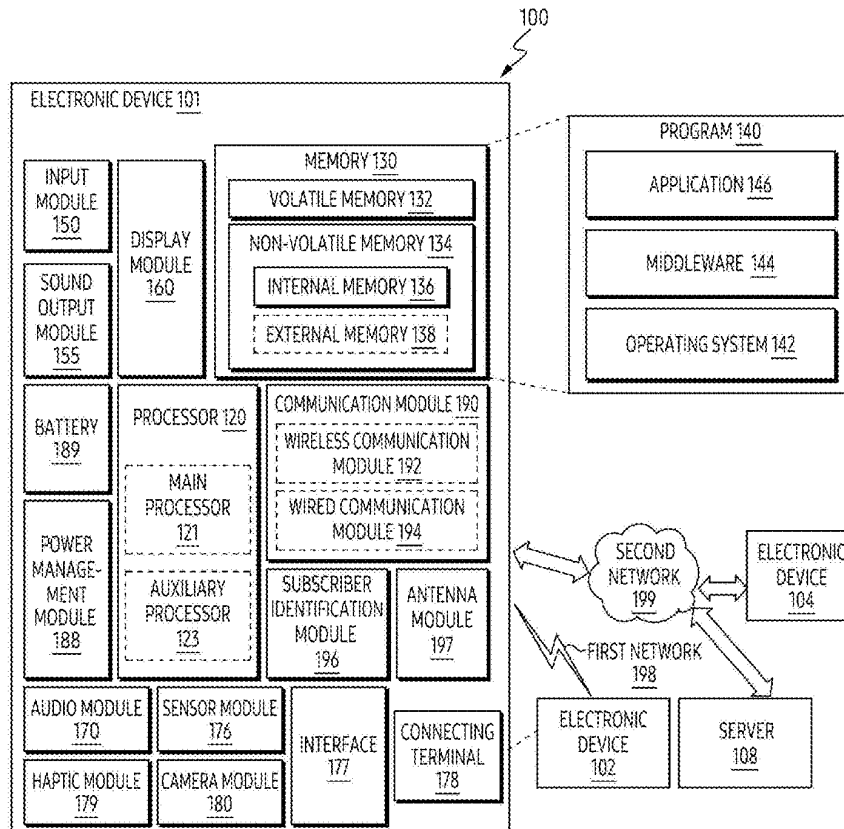



US 20250202562A1

(19) **United States**

(12) **Patent Application Publication**  
**RAGHAVAN et al.**

(10) **Pub. No.: US 2025/0202562 A1**

(43) **Pub. Date: Jun. 19, 2025**

(54) **USER EQUIPMENT (UE) ANTENNA  
MODULE LOCK FUNCTION**

(52) **U.S. Cl.**  
CPC ..... **H04B 7/0695** (2013.01); **H04B 7/0639**  
(2013.01)

(71) Applicant: **QUALCOMM Incorporated**, San Diego, CA (US)

(57) **ABSTRACT**

(72) Inventors: **Vasanthan RAGHAVAN**, West Windsor Township, NJ (US); **Benjamin CHEADLE**, San Diego, CA (US); **Raghu Narayan CHALLA**, San Diego, CA (US); **Mohammad Ali TASSOUDJI**, San Diego, CA (US)

Methods, systems, and devices for wireless communications systems are described. A user equipment (UE) may receive, from a network entity, a set of beam-swept synchronization signals associated with a testing procedure for the UE. The UE may select a first beam pair associated with a first antenna module of the UE from a set of multiple beam pairs associated with the received synchronization signals. The UE may receive a first module lock command and a first beam lock command, and may utilize the commands in performing a first set of measurements of the first beam pair at the first antenna module. The UE may receive a first beam lock deactivation command to release the first beam lock command of the first beam pair, and a first module lock deactivation command to release the first module lock command of the first antenna module.

(21) Appl. No.: **18/541,721**

(22) Filed: **Dec. 15, 2023**

**Publication Classification**

(51) **Int. Cl.**  
**H04B 7/06** (2006.01)

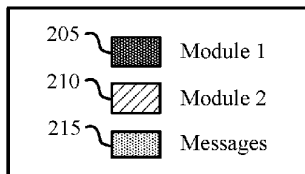
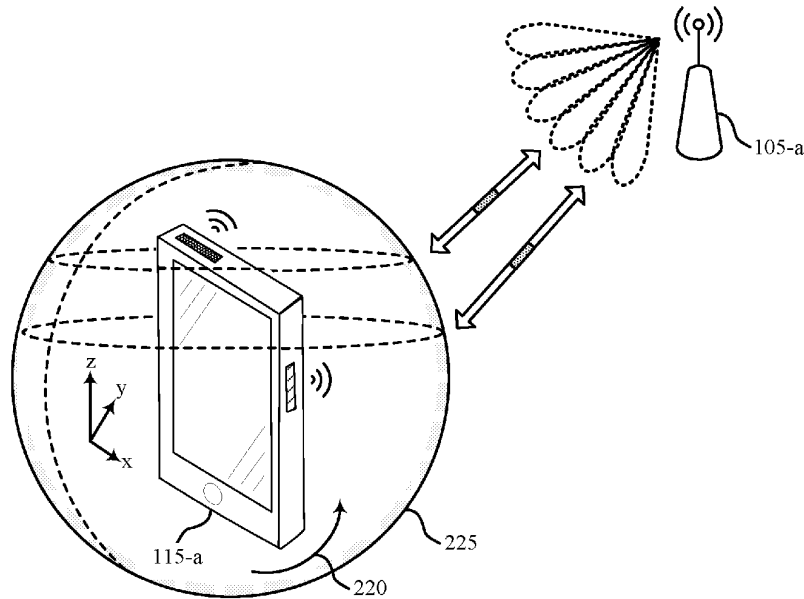



(19) **United States**

(12) **Patent Application Publication**  
**RAGHAVAN et al.**

(10) **Pub. No.: US 2025/0202567 A1**

(43) **Pub. Date: Jun. 19, 2025**

(54) **CONFORMANCE TESTING FOR A USER EQUIPMENT UNDER BLOCKAGE CONDITIONS**

(52) **U.S. Cl.**  
CPC ..... **H04B 7/0696** (2023.05); **H04B 17/328** (2023.05); **H04W 24/10** (2013.01); **H04W 56/0015** (2013.01)

(71) Applicant: **QUALCOMM Incorporated**, San Diego, CA (US)

(57) **ABSTRACT**

(72) Inventors: **Vasanthan RAGHAVAN**, West Windsor Township, NJ (US); **Raghu Narayan CHALLA**, San Diego, CA (US); **Benjamin CHEADLE**, San Diego, CA (US); **Mohammad Ali TASSOUDJI**, San Diego, CA (US)

Methods, systems, and devices for wireless communications are described. A user equipment (UE) may receive, from a network entity, beam-swept synchronization signals. The UE may select a first beam pair from a set of beam pairs associated with the set of beam-swept synchronization signals. The UE may perform one or more freespace spherical coverage measurements of a first antenna module based on selecting the first beam pair. The UE may calculate one or more blockage-impaired spherical coverage metrics of the first antenna module based on the one or more freespace spherical coverage measurements and a blockage transformation. The UE may calculate a predictive spherical coverage value of the UE in a blockage environment based on the one or more blockage-impaired spherical coverage metrics of the first antenna module and may calculate a conformance metric for the UE.

(21) Appl. No.: **18/542,188**

(22) Filed: **Dec. 15, 2023**

**Publication Classification**

(51) **Int. Cl.**  
**H04B 7/06** (2006.01)  
**H04B 17/318** (2015.01)  
**H04W 24/10** (2009.01)  
**H04W 56/00** (2009.01)

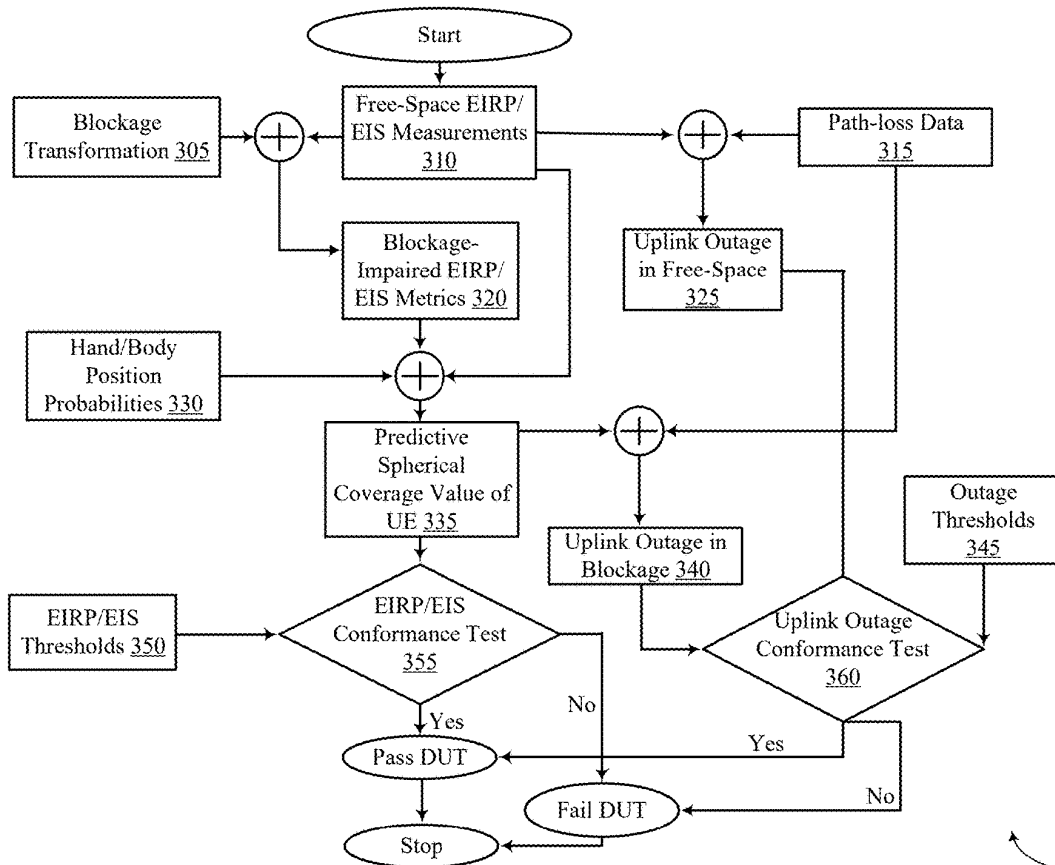



US 20250202570A1

(19) **United States**

(12) **Patent Application Publication**  
**PICK et al.**

(10) **Pub. No.: US 2025/0202570 A1**

(43) **Pub. Date: Jun. 19, 2025**

(54) **NETWORK CONTROLLED UE ANALOG RECEPTION PRECODING**

(52) **U.S. Cl.**  
CPC ..... **H04B 7/086** (2013.01); **H04L 5/005** (2013.01)

(71) Applicant: **QUALCOMM Incorporated**, San Diego, CA (US)

(57) **ABSTRACT**

(72) Inventors: **Jacob PICK**, Mevaseret Zion (IL); **Assaf TOUBOUL**, Netanya (IL); **Shay LANDIS**, Hod Hasharon (IL); **Gideon Shlomo KUTZ**, Ramat Hasharon (IL); **Guy WOLF**, Rosh Haayin (IL); **Peer BERGER**, Hod Hasharon (IL); **Tomer GEVA**, Kiryat Ono (IL)

The apparatus may be a UE configured to obtain a configuration for an antenna identification associated with a plurality of antennas at the UE, output, for a network device and based on the configuration for the antenna identification, a set of antenna identification signals, and obtain, based on the set of antenna identification signals, analog reception combining information. The apparatus may also be configured to communicate with the network device based on the analog reception combining information. The apparatus may be a network device configured to output a configuration for an antenna identification associated with a plurality of antennas at a UE, obtain, from the UE and based on the configuration for the antenna identification, a set of antenna identification signals, and output, based on the set of antenna identification signals, analog reception combining information.

(21) Appl. No.: **18/389,685**

(22) Filed: **Dec. 19, 2023**

**Publication Classification**

(51) **Int. Cl.**  
**H04B 7/08** (2006.01)  
**H04L 5/00** (2006.01)

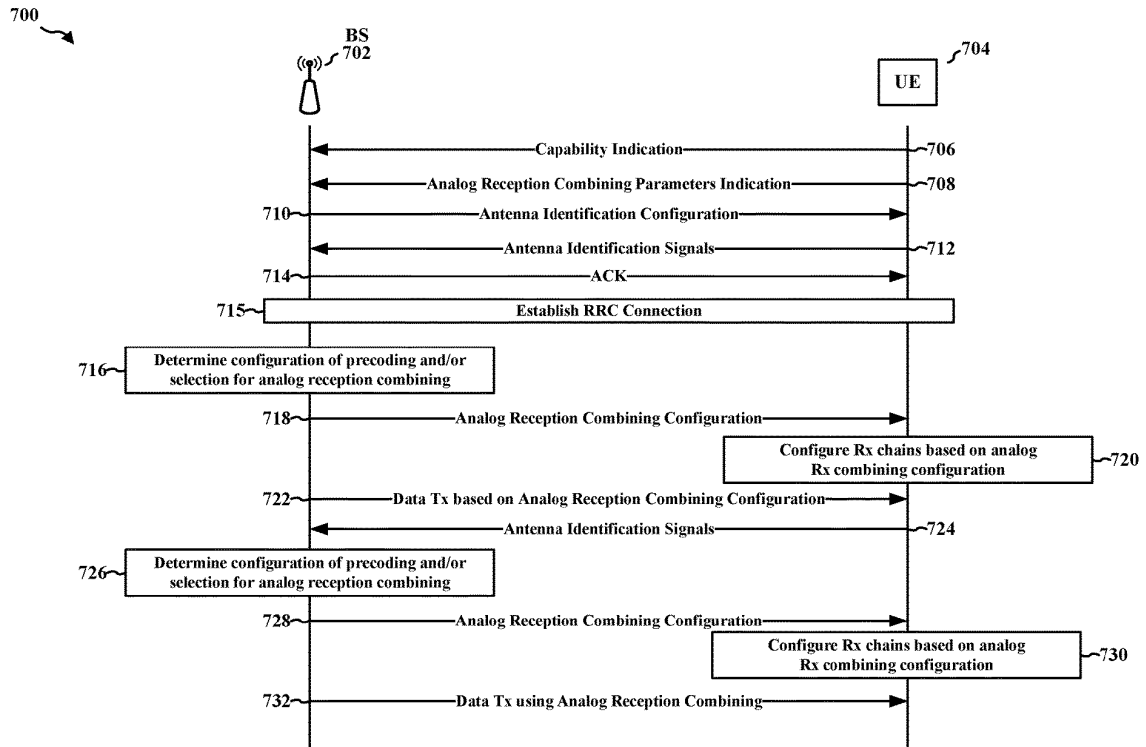



US 20250202656A1

(19) **United States**

(12) **Patent Application Publication**  
FAN et al.

(10) **Pub. No.: US 2025/0202656 A1**

(43) **Pub. Date: Jun. 19, 2025**

(54) **PORT CONFIGURATION METHOD,  
APPARATUS, AND SYSTEM**

(52) **U.S. Cl.**  
CPC ..... *H04L 5/0051* (2013.01); *H04W 8/24*  
(2013.01); *H04W 72/1268* (2013.01)

(71) Applicant: **HUAWEI TECHNOLOGIES CO.,  
LTD.**, Shenzhen (CN)

(72) Inventors: **Bo FAN**, Chengdu (CN); **Shitong  
YUAN**, Chengdu (CN); **Fang LI**,  
Chengdu (CN)

(57) **ABSTRACT**

(21) Appl. No.: **19/050,940**

(22) Filed: **Feb. 11, 2025**

**Related U.S. Application Data**

(63) Continuation of application No. PCT/CN2023/  
105437, filed on Jun. 30, 2023.

(30) **Foreign Application Priority Data**

Aug. 12, 2022 (CN) ..... 202210968855.8

**Publication Classification**

(51) **Int. Cl.**  
*H04L 5/00* (2006.01)  
*H04W 8/24* (2009.01)  
*H04W 72/1268* (2023.01)

This application provides a port configuration method, an apparatus, and a system. The port configuration method provided in this application includes: First, a terminal device sends first indication information to a network device, where the first indication information is used to determine a codebook capability of the terminal device. Then, the terminal device receives first configuration information from the network device, where the first configuration information indicates information about a phase tracking reference signal (PTRS) port configured by the network device for the terminal device, and the information about the PTRS port configured by the network device for the terminal device is determined based on the codebook capability of the terminal device. The terminal device determines, based on the configured PTRS port, a PTRS port corresponding to uplink transmission. The method may be applied to a multi-antenna panel uplink simultaneous transmission (or referred to as multi-beam uplink simultaneous transmission) scenario.

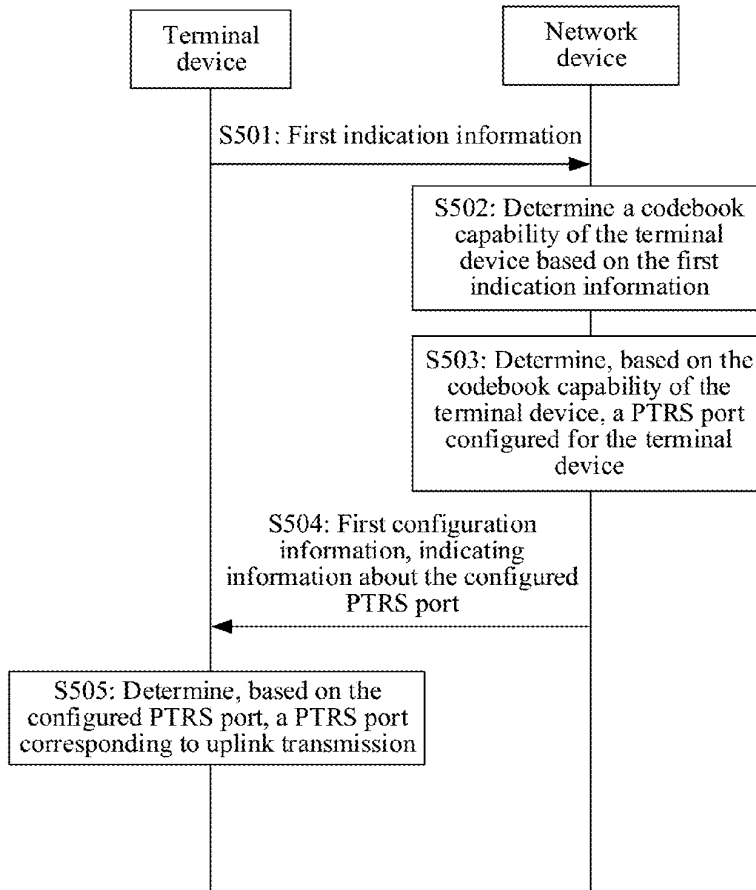



(19) **United States**

(12) **Patent Application Publication** (10) **Pub. No.: US 2025/0202659 A1**

**LI et al.**

(43) **Pub. Date: Jun. 19, 2025**

(54) **SRS TRANSMISSION METHOD AND APPARATUS**

(52) **U.S. Cl.**  
CPC ..... **H04L 5/0051** (2013.01); **H04B 7/0404** (2013.01)

(71) Applicant: **HUAWEI TECHNOLOGIES CO., LTD.**, Shenzhen (CN)

(72) Inventors: **Xi LI**, Beijing (CN); **Shijie CAI**, Shenzhen (CN); **Xiang GAO**, Beijing (CN); **Kunpeng LIU**, Beijing (CN)

(57) **ABSTRACT**

(21) Appl. No.: **19/066,572**

(22) Filed: **Feb. 28, 2025**

This application provides an SRS transmission method and apparatus, and the method is jointly performed by a terminal device and a network device. The SRS transmission method in this application includes: The network device sends configuration information of an SRS resource set to the terminal device. The terminal device obtains the SRS resource set. The terminal device determines a first antenna set and a second antenna set. The terminal device determines an antenna corresponding to at least one port included in each of a plurality of SRS resources. The terminal device sends an SRS for measuring an uplink channel of the corresponding antenna to a base station through the at least one port included in each SRS resource. The network device receives, through the at least one port included in each of the plurality of SRS resources, the SRS sent by the terminal device.

**Related U.S. Application Data**

(63) Continuation of application No. PCT/CN2023/103643, filed on Jun. 29, 2023.

**Foreign Application Priority Data**

Aug. 31, 2022 (CN) ..... 202211058367.X

**Publication Classification**

(51) **Int. Cl.**  
**H04L 5/00** (2006.01)  
**H04B 7/0404** (2017.01)

500

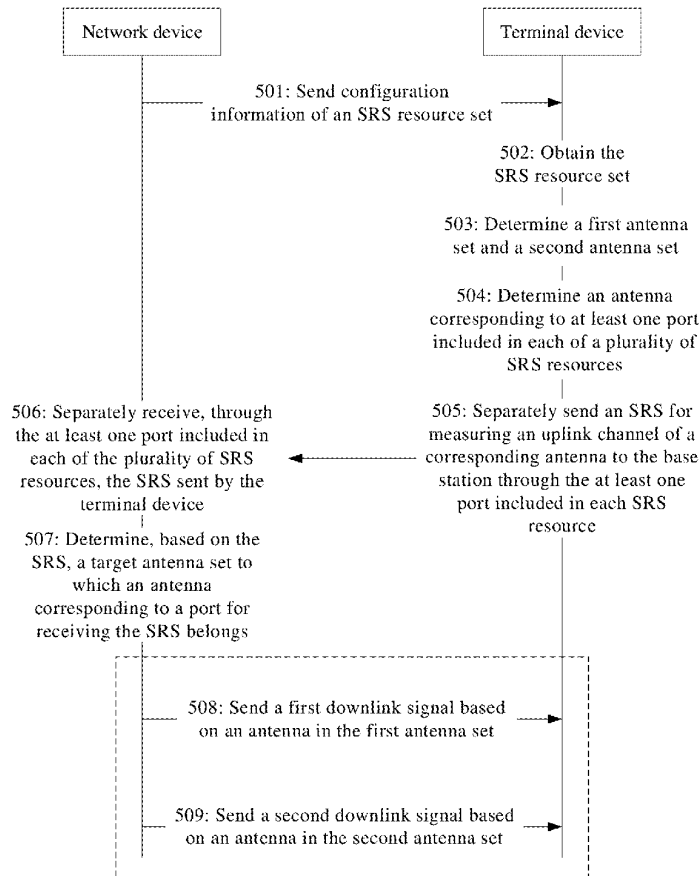



(19) **United States**

(12) **Patent Application Publication**  
**LI et al.**

(10) **Pub. No.: US 2025/0202660 A1**

(43) **Pub. Date: Jun. 19, 2025**

(54) **SRS TRANSMISSION METHOD AND APPARATUS**

**Publication Classification**

(71) Applicant: **HUAWEI TECHNOLOGIES CO., LTD.**, Shenzhen (CN)

(51) **Int. Cl.**  
**H04L 5/00** (2006.01)  
**H04L 27/26** (2006.01)  
**H04W 8/22** (2009.01)

(72) Inventors: **Xi LI**, Beijing (CN); **Shijie CAI**, Shenzhen (CN); **Kunpeng LIU**, Beijing (CN)

(52) **U.S. Cl.**  
CPC ..... **H04L 5/0051** (2013.01); **H04L 27/2605** (2013.01); **H04W 8/22** (2013.01)

(21) Appl. No.: **19/066,578**

(57) **ABSTRACT**

(22) Filed: **Feb. 28, 2025**

This application provides an SRS transmission method and apparatus. The SRS transmission method in this application includes: A network device sends configuration information of an SRS resource set to a terminal device, where the SRS resource set includes a first SRS resource and a second SRS resource, and the first SRS resource and the second SRS resource each include four ports. The terminal device determines a first antenna set and a second antenna set, and determines antennas respectively corresponding to the four ports included in the first SRS resource and antennas respectively corresponding to the four ports included in the second SRS resource. The terminal device separately sends an SRS to a base station through the four ports included in the first SRS resource and the four ports included in the second SRS resource.

**Related U.S. Application Data**

(63) Continuation of application No. PCT/CN2023/104042, filed on Jun. 29, 2023.

(30) **Foreign Application Priority Data**

Aug. 31, 2022 (CN) ..... 202211058349.1

500

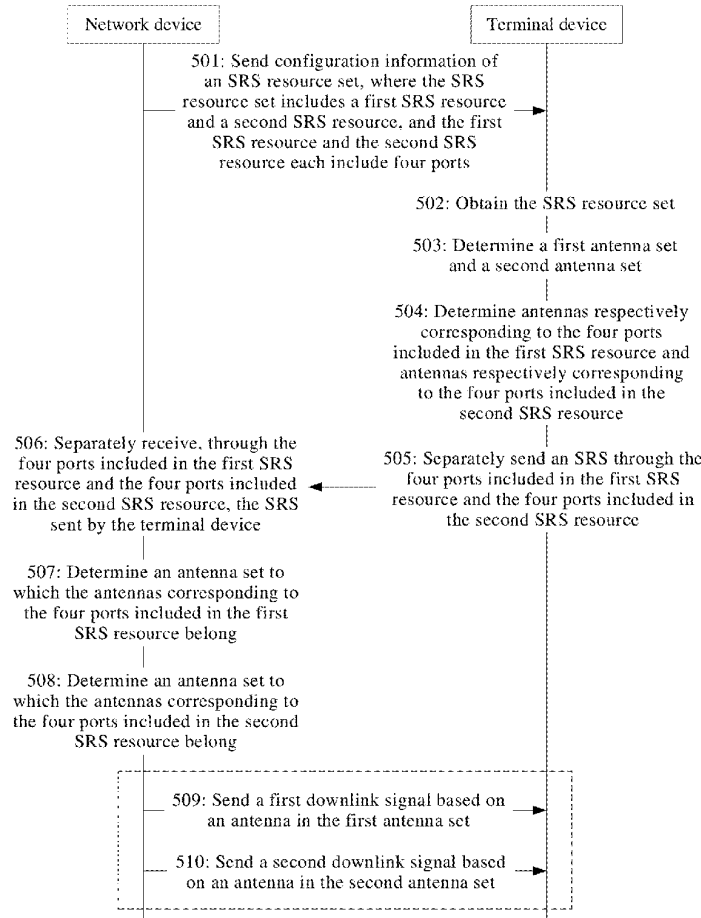



US 20250203530A1

(19) **United States**

(12) **Patent Application Publication**  
**LING et al.**

(10) **Pub. No.: US 2025/0203530 A1**

(43) **Pub. Date: Jun. 19, 2025**

(54) **METHOD AND ELECTRONIC DEVICE FOR TUNING AN ANTENNA**

**Publication Classification**

(71) Applicant: **Samsung Electronics Co., Ltd.**,  
Suwon-si (KR)

(51) **Int. Cl.**  
**H04W 52/36** (2009.01)  
**H04W 52/24** (2009.01)

(72) Inventors: **Yue LING**, Beijing (CN); **Hua CHEN**,  
Beijing (CN); **Yingxin XIANG**, Beijing  
(CN)

(52) **U.S. Cl.**  
CPC ..... **H04W 52/36** (2013.01); **H04W 52/242**  
(2013.01)

(21) Appl. No.: **18/806,115**

(57) **ABSTRACT**

(22) Filed: **Aug. 15, 2024**

An antenna tuning method, an antenna tuning device, an electronic apparatus, and/or a related storage medium may be provided. The antenna tuning method may include: determining a maximum and/or high radiated power of an antenna in response to detecting an abnormality of a transmitting state of the antenna; determining a headroom condition of the maximum and/or high radiated power for a current service type based on network parameters; determining a target receiving power based on the headroom condition; determining a tuning parameter corresponding to the target receiving power as a tuning parameter of the antenna.

**Related U.S. Application Data**

(63) Continuation of application No. PCT/KR2024/011524, filed on Aug. 5, 2024.

**Foreign Application Priority Data**

Dec. 15, 2023 (CN) ..... 202311735990.9

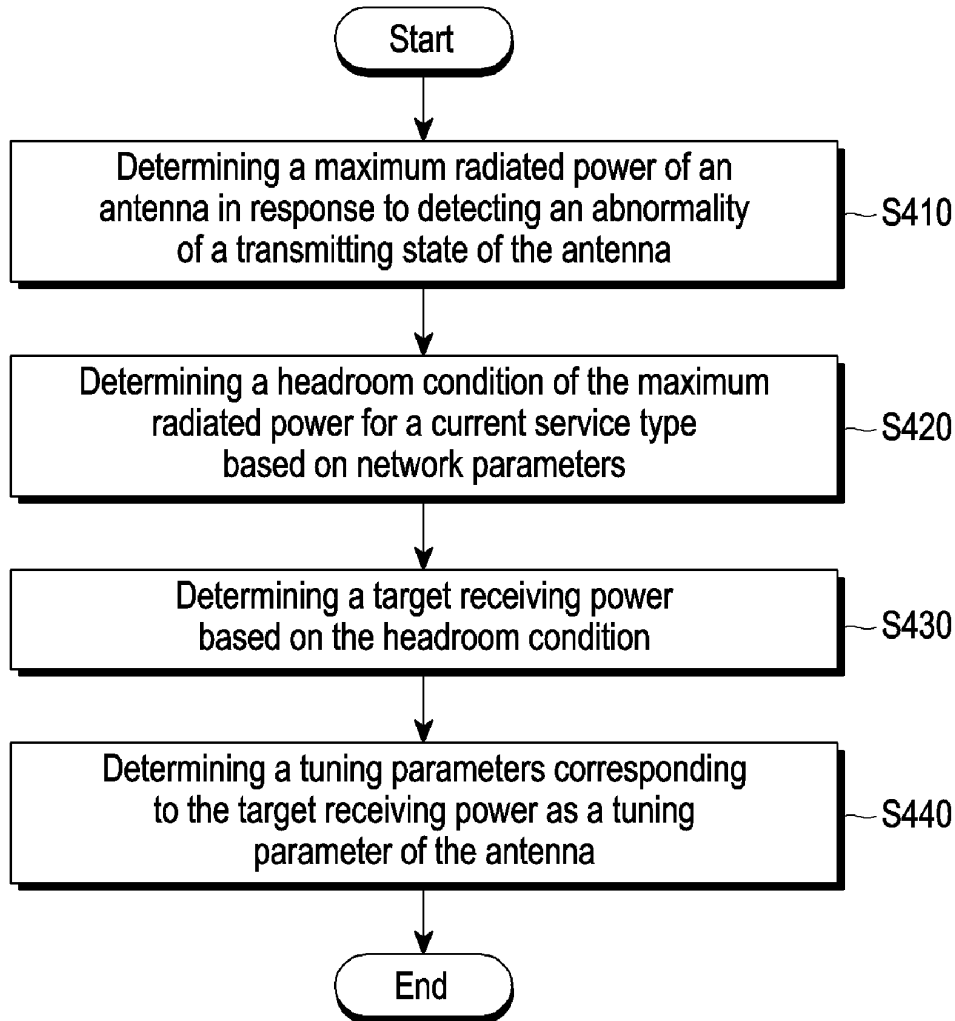



US 20250210849A1

(19) **United States**

(12) **Patent Application Publication** (10) **Pub. No.: US 2025/0210849 A1**

**Rao et al.**

(43) **Pub. Date: Jun. 26, 2025**

(54) **LAPTOP COMPUTER WITH PHASED ANTENNA ARRAY**

(52) **U.S. Cl.**  
CPC ..... **H01Q 1/2266** (2013.01); **H01Q 3/36** (2013.01)

(71) Applicant: **Apple Inc.**, Cupertino, CA (US)

(57) **ABSTRACT**

(72) Inventors: **Menglou Rao**, Austin, TX (US); **Jerzy S. Guterman**, Sunnyvale, CA (US); **Panagiotis Theofanopoulos**, Cupertino, CA (US); **Joel D. Barrera**, Cedar Park, TX (US)

An electronic device such as a laptop computer may have upper and lower housings. The upper housing may be coupled to the lower housing by a hinge having a hinge axis. The lower housing may have an upper metal wall, a lower metal wall, and an angled metal wall that extends from the upper metal wall towards the lower metal wall. The lower housing may include a phased antenna array with a set of antennas aligned along a linear axis. The phased antenna array may be aligned with a dielectric window in the upper metal wall and may be oriented such that the linear axis is orthogonal to the hinge axis, or may be aligned with a dielectric window in the angled metal wall. One or more processors may adjust the phased antenna array based on the position of the upper housing relative to the lower housing.

(21) Appl. No.: **18/390,678**

(22) Filed: **Dec. 20, 2023**

**Publication Classification**

(51) **Int. Cl.**  
**H01Q 1/22** (2006.01)  
**H01Q 3/36** (2006.01)

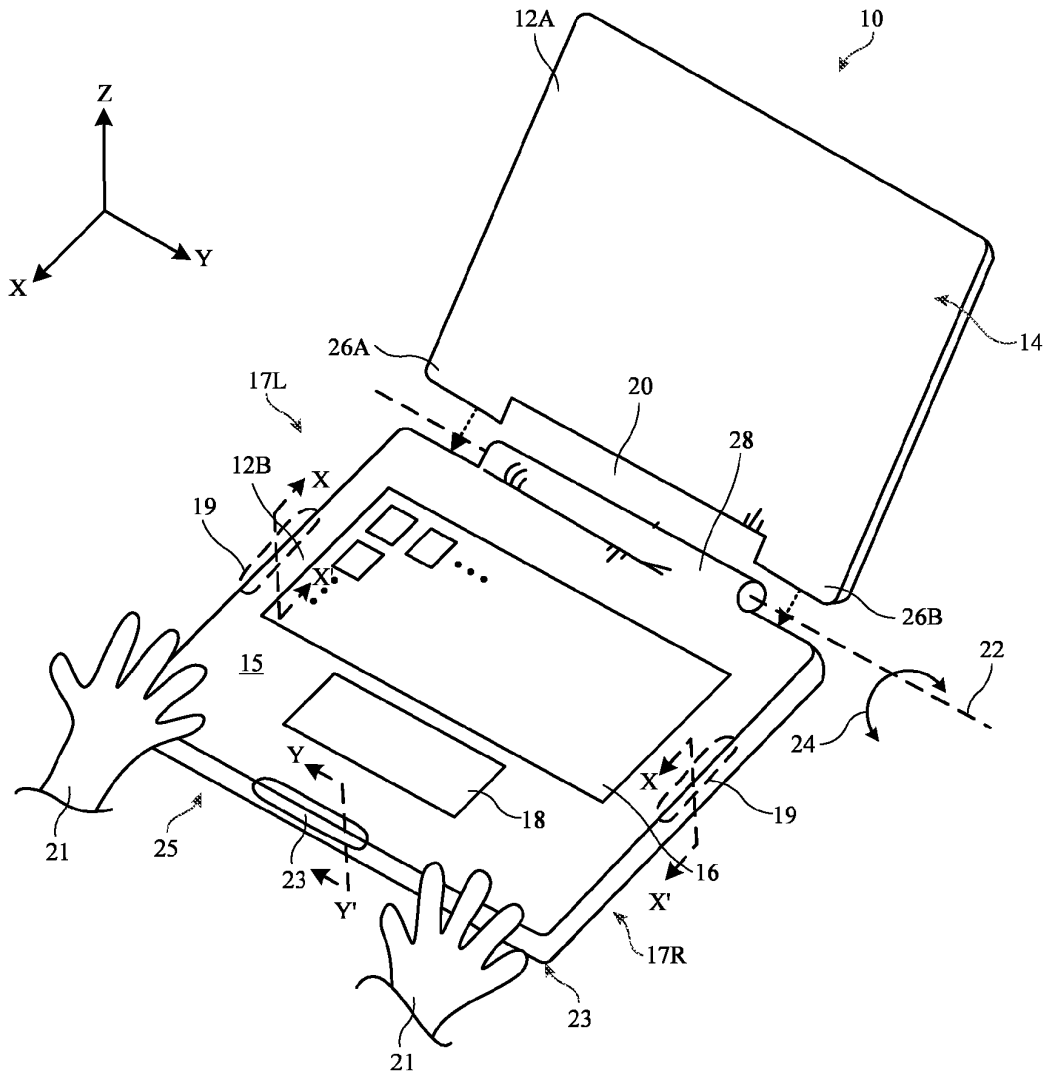



US 20250210850A1

(19) **United States**

(12) **Patent Application Publication** (10) **Pub. No.: US 2025/0210850 A1**  
**Barrera et al.** (43) **Pub. Date: Jun. 26, 2025**

(54) **ELECTRONIC DEVICE ANTENNA WITH SHEET METAL CAVITY**

(52) **U.S. Cl.**  
CPC ..... **H01Q 1/2266** (2013.01)

(71) Applicant: **Apple Inc.**, Cupertino, CA (US)

(57) **ABSTRACT**

(72) Inventors: **Joel D. Barrera**, Cedar Park, TX (US);  
**Rhett D. Gentile**, San Francisco, CA (US);  
**Menglou Rao**, Austin, TX (US);  
**Jerzy S. Guterman**, Sunnyvale, CA (US);  
**Daniel D. Hershey**, Portland, OR (US)

A laptop computer may have a lower housing with an antenna module. The antenna module may include first and second pieces of sheet metal that form a cavity. The cavity may have an aperture covered by a dielectric layer. The first piece of sheet metal may be bent towards the second piece and may be welded to the second piece at a side of the cavity opposite the aperture. An antenna arm may be disposed within the cavity and mounted to the second piece. The antenna arm may be laterally separated from the dielectric layer by a non-zero distance. A dielectric loading block may be disposed within the cavity and mounted to the second piece. The antenna arm may be mounted to a side of the dielectric loading block facing the aperture and the dielectric layer. The antenna arm may convey radio-frequency signals through the aperture and the dielectric layer.

(21) Appl. No.: **18/391,282**

(22) Filed: **Dec. 20, 2023**

**Publication Classification**

(51) **Int. Cl.**  
**H01Q 1/22** (2006.01)

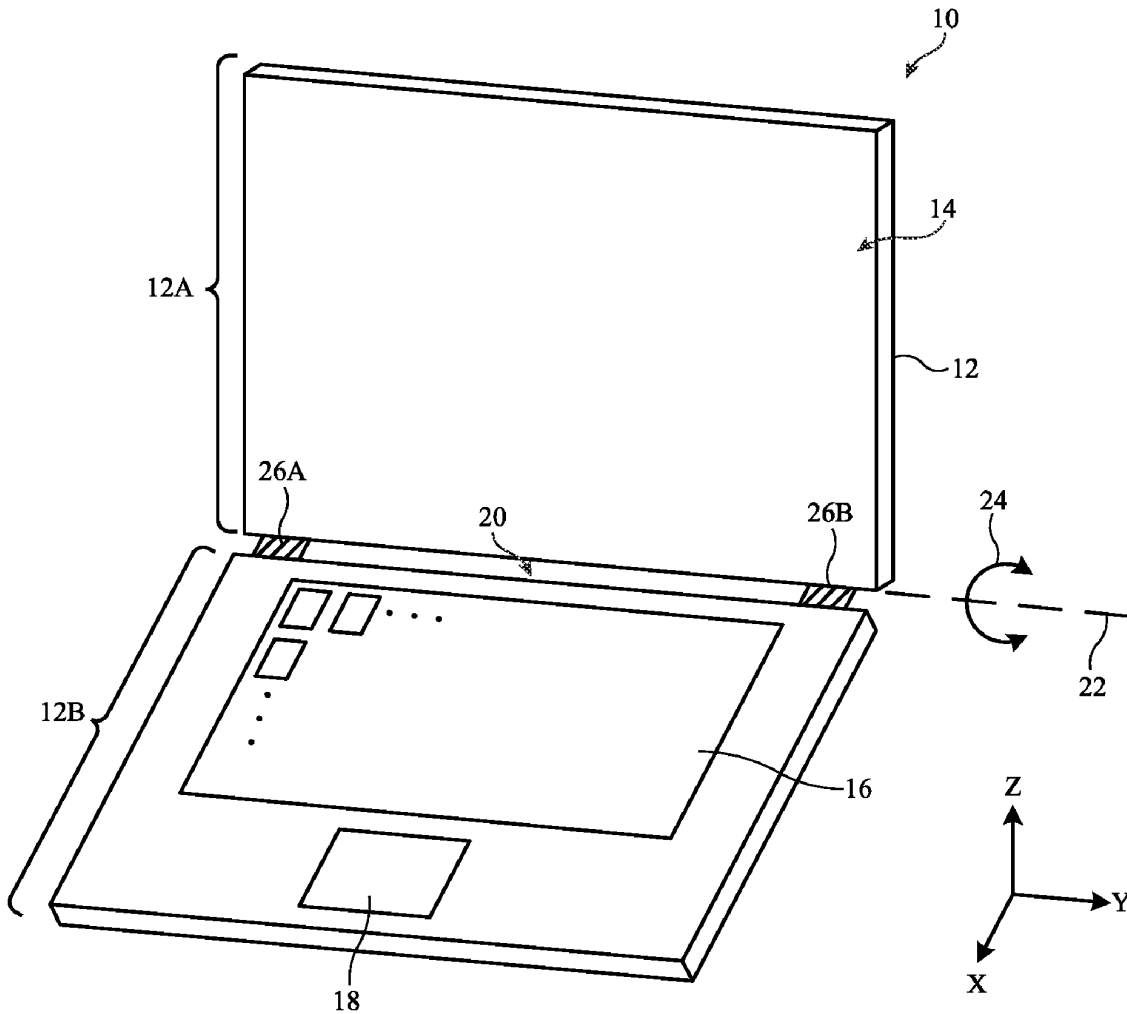



US 20250210851A1

(19) **United States**

(12) **Patent Application Publication**  
**LOU et al.**

(10) **Pub. No.: US 2025/0210851 A1**

(43) **Pub. Date: Jun. 26, 2025**

(54) **WIRELESS COMMUNICATION DEVICE  
AND WIRELESS COMMUNICATION  
SYSTEM**

(52) **U.S. Cl.**  
CPC ..... **H01Q 1/2266** (2013.01); **H01Q 1/24**  
(2013.01); **H01Q 13/10** (2013.01)

(71) Applicant: **QuantumZ Inc.**, Kaohsiung City (TW)

(72) Inventors: **Chih Yang LOU**, Kaohsiung City  
(TW); **Meng-Hua TSAI**, Kaohsiung  
City (TW); **Sin-Siang WANG**,  
Kaohsiung City (TW); **Wei Ting LEE**,  
Kaohsiung City (TW)

(57) **ABSTRACT**

A wireless communication device includes an antenna module and a flexible substrate. The antenna module includes an antenna structure and a control chip. The control chip is configured to use an antenna structure to perform wireless communication. The flexible substrate is used to carry the antenna module and includes two substrate regions. The antenna structure includes a first antenna radiation plate and a second antenna radiation plate. An open slot is extended from an edge of the first antenna radiation plate to a center of the first antenna radiation plate. The second antenna radiation plate is disposed under the first antenna radiation plate to overlap the first antenna radiation plate. There is a distance between the first antenna radiation plate and the second antenna radiation plate, thus the second antenna radiation plate is coupled to the first antenna radiation plate.

(21) Appl. No.: **18/929,645**

(22) Filed: **Oct. 29, 2024**

(30) **Foreign Application Priority Data**

Dec. 25, 2023 (TW) ..... 112150633

**Publication Classification**

(51) **Int. Cl.**  
**H01Q 1/22** (2006.01)  
**H01Q 1/24** (2006.01)  
**H01Q 13/10** (2006.01)

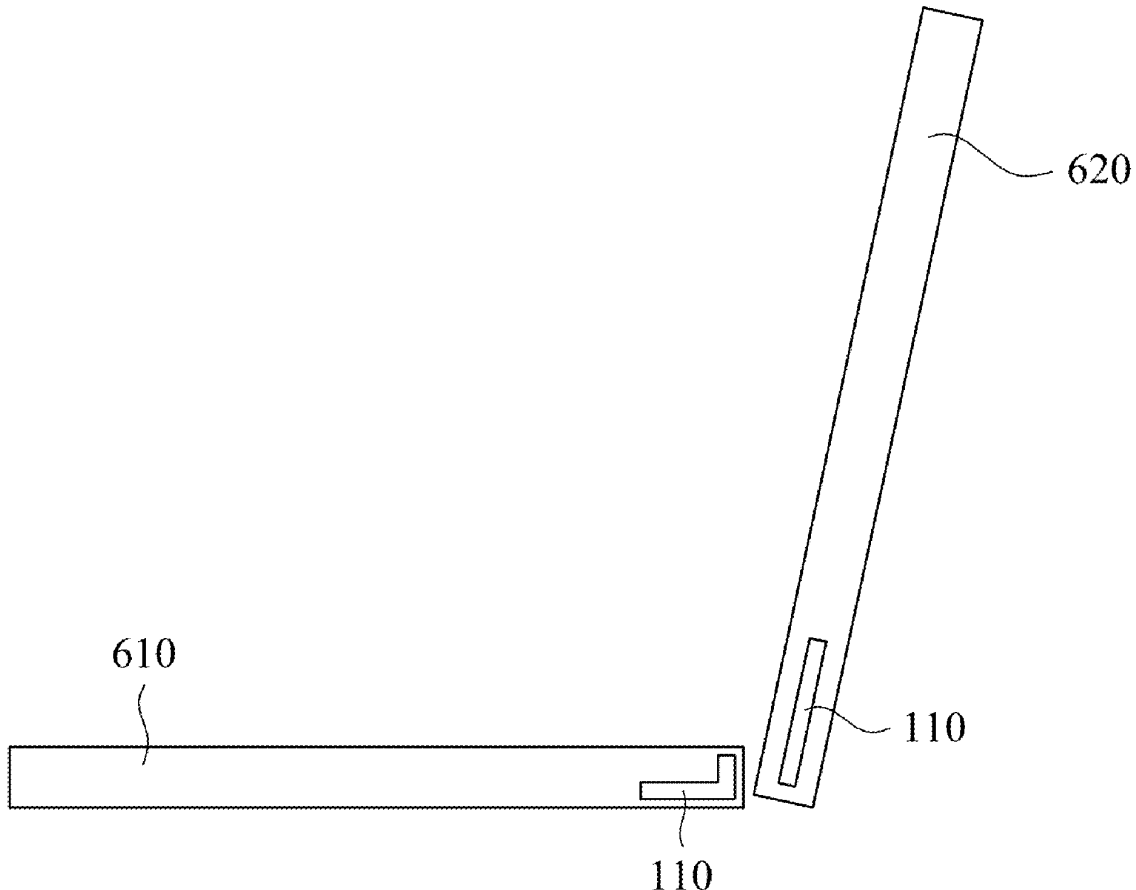



US 20250210857A1

(19) **United States**

(12) **Patent Application Publication**  
**Li et al.**

(10) **Pub. No.: US 2025/0210857 A1**

(43) **Pub. Date: Jun. 26, 2025**

(54) **INTEGRATED MULTI-FEED ANTENNA**

(52) **U.S. Cl.**

CPC ..... **H01Q 1/50** (2013.01); **H01Q 1/36** (2013.01)

(71) Applicant: **Industrial Technology Research Institute, Hsinchu (TW)**

(57)

**ABSTRACT**

(72) Inventors: **Wei-Yu Li, Hsinchu City (TW); Wei Chung, Hsinchu County (TW); Kin-Lu Wong, Kaohsiung City (TW)**

The disclosure provides an integrated multi-feed antenna, including a first conductor layer, a second conductor layer, and multiple feeding conductor lines. The second conductor layer has a first center position. The second conductor layer has a closed slit structure. The closed slit structure surrounds the first center position to encircle forming a center region. The second conductor layer is spaced apart from the first conductor layer at a first interval. Each of the feeding conductor lines has one end electrically connected or electrically coupled to the second conductor layer, and each has another end electrically connected to a signal source. Each of the feeding conductor lines excites the second conductor layer to generate at least one resonant mode. The resonant modes cover at least one identical wireless communication band.

(73) Assignee: **Industrial Technology Research Institute, Hsinchu (TW)**

(21) Appl. No.: **18/395,750**

(22) Filed: **Dec. 26, 2023**

**Publication Classification**

(51) **Int. Cl.**  
**H01Q 1/50** (2006.01)  
**H01Q 1/36** (2006.01)

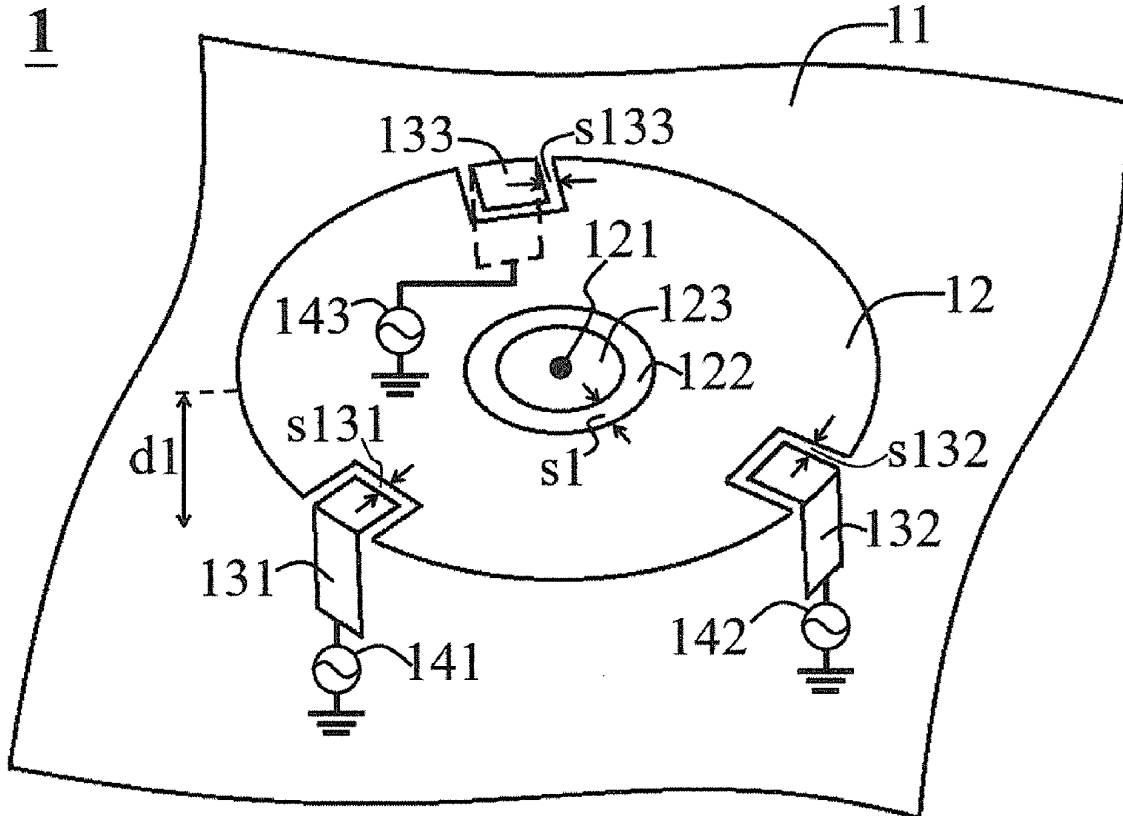



(19) **United States**

(12) **Patent Application Publication**  
**Isaksen et al.**

(10) **Pub. No.: US 2025/0210883 A1**

(43) **Pub. Date: Jun. 26, 2025**

(54) **SYSTEM, METHOD AND APPARATUS FOR HIGH-SPEED WIRELESS COMMUNICATION THROUGH HIGH-LOSS OBSTRUCTION**

(52) **U.S. Cl.**  
CPC ..... **H01Q 21/24** (2013.01); **H04B 7/0413** (2013.01); **H04L 27/34** (2013.01)

(71) Applicant: **Airvine Scientific, Inc.**, Santa Clara, CA (US)

(57) **ABSTRACT**

(72) Inventors: **David Bruce Isaksen**, San Jose, CA (US); **Morteza Sheikhsoufa**, San Jose, CA (US); **Ehsan Afshari**, Ann Arbor, MI (US); **Darin Milton**, Campbell, CA (US)

Disclosed are one or more apparatuses, systems and methods that allow microwave communications signals to pass efficiently and reliably through high-loss obstructions, such as concrete structures. For example, a concrete-penetrating microwave apparatus includes a wireless microwave transceiver coupled to a multiple input multiple output (MIMO) antenna. The transceiver processes wireless microwave signals transmitted and received by the MIMO antenna through one or more obstructions. The MIMO antenna and transceiver are configured to compensate for path loss experienced by the microwave signals as they pass through the lossy obstruction so as to maintain the desired data rate of the wireless microwave signals. Concrete-penetrating microwave apparatuses may be paired together and aimed at each other, with one apparatus on either side of an obstruction, to allow high-speed networked microwave communication directly through the otherwise microwave-impenetrable obstruction. This permits high-bandwidth communications throughout buildings or other structures without having to install expensive wall/floor-penetrating cable.

(73) Assignee: **Airvine Scientific, Inc.**, Santa Clara, CA (US)

(21) Appl. No.: **18/985,805**

(22) Filed: **Dec. 18, 2024**

**Related U.S. Application Data**

(60) Provisional application No. 63/613,401, filed on Dec. 21, 2023.

**Publication Classification**

(51) **Int. Cl.**  
**H01Q 21/24** (2006.01)  
**H04B 7/0413** (2017.01)  
**H04L 27/34** (2006.01)

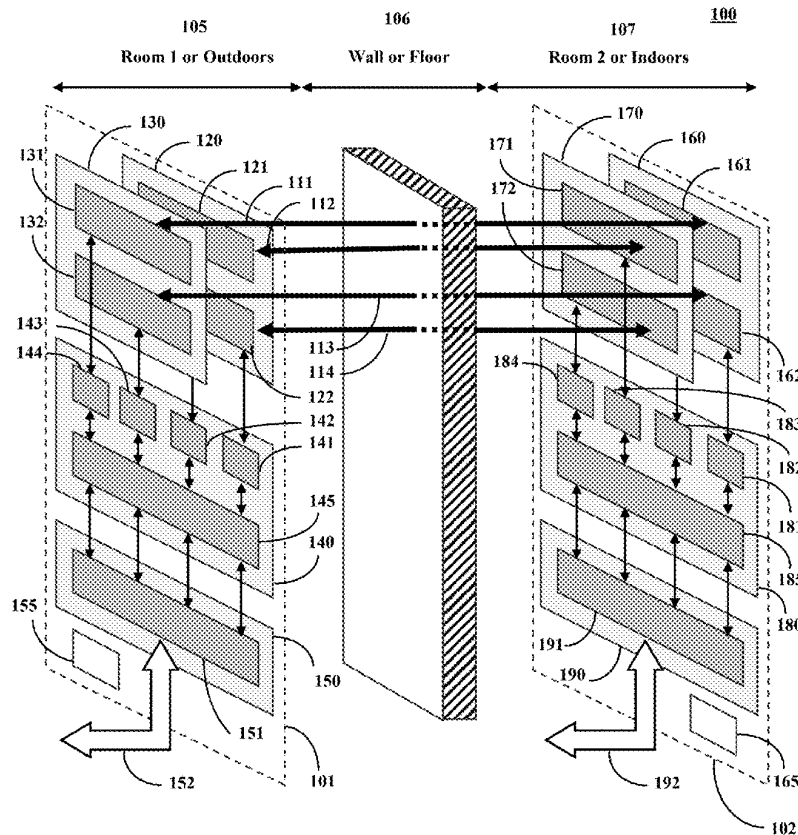



(19) **United States**

(12) **Patent Application Publication**  
**ZHU et al.**

(10) **Pub. No.: US 2025/0219282 A1**

(43) **Pub. Date: Jul. 3, 2025**

(54) **SENSING MODULE AND ELECTRONIC DEVICE**

**Publication Classification**

(71) Applicant: **Wistron NeWeb Corporation**, Hsinchu (TW)

(51) **Int. Cl.**  
**H01Q 1/22** (2006.01)  
**G01D 5/24** (2006.01)  
**H01Q 1/50** (2006.01)  
**H01Q 1/52** (2006.01)

(72) Inventors: **Jia-Le ZHU**, Hsinchu (TW);  
**Ching-Wen CHEN**, Hsinchu (TW);  
**Cheng-Wei CHIANG**, Hsinchu (TW);  
**Li-Kai KUO**, Hsinchu (TW)

(52) **U.S. Cl.**  
CPC ..... **H01Q 1/2266** (2013.01); **G01D 5/24** (2013.01); **H01Q 1/50** (2013.01); **H01Q 1/52** (2013.01)

(21) Appl. No.: **18/981,805**

(57) **ABSTRACT**

(22) Filed: **Dec. 16, 2024**

A sensing module includes a first antenna unit, a second antenna unit, a first inductor and a proximity sensor. The first antenna unit has at least one first communication frequency band, and the second antenna unit has at least one second communication frequency band. The first antenna unit and the second antenna unit are connected in parallel to one end of the first inductor, and the other end of the first inductor is electrically connected to the proximity sensor.

(30) **Foreign Application Priority Data**

Dec. 28, 2023 (TW) ..... 112151212

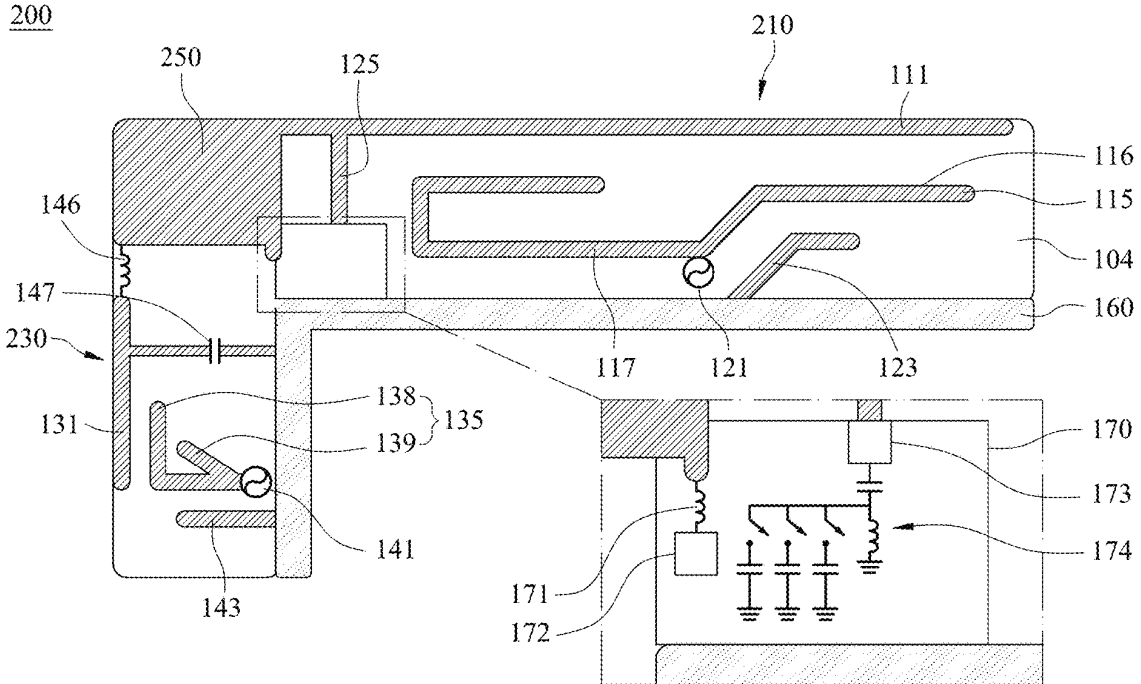



US 20250219288A1

(19) **United States**

(12) **Patent Application Publication**  
**Lee**

(10) **Pub. No.: US 2025/0219288 A1**

(43) **Pub. Date: Jul. 3, 2025**

(54) **ANTENNA DEVICE AND DISPLAY DEVICE INCLUDING AN ANTENNA UNIT**

(52) **U.S. Cl.**  
CPC ..... **H01Q 3/24** (2013.01); **H01Q 1/50** (2013.01)

(71) Applicant: **LG Display Co., Ltd.**, Seoul (KR)

(72) Inventor: **HyunKyu Lee**, Paju-si (KR)

(57) **ABSTRACT**

(73) Assignee: **LG Display Co., Ltd.**, Seoul (KR)

(21) Appl. No.: **18/886,166**

(22) Filed: **Sep. 16, 2024**

(30) **Foreign Application Priority Data**

Dec. 28, 2023 (KR) ..... 10-2023-0195163

**Publication Classification**

(51) **Int. Cl.**  
**H01Q 3/24** (2006.01)  
**H01Q 1/50** (2006.01)

Embodiments of the disclosure relate to a display device and display panel including a reconfigurable antenna. The display device may include: a substrate including a display area configured to display an image and a non-display area not configured to display an image; a pixel unit including a plurality of pixels disposed in the display area; and an antenna unit disposed in at least a portion of the display area or at least a portion of the non-display area. The antenna unit may include a plurality of radiators and an antenna constituent circuit configuring an antenna with at least one of the plurality of radiators.

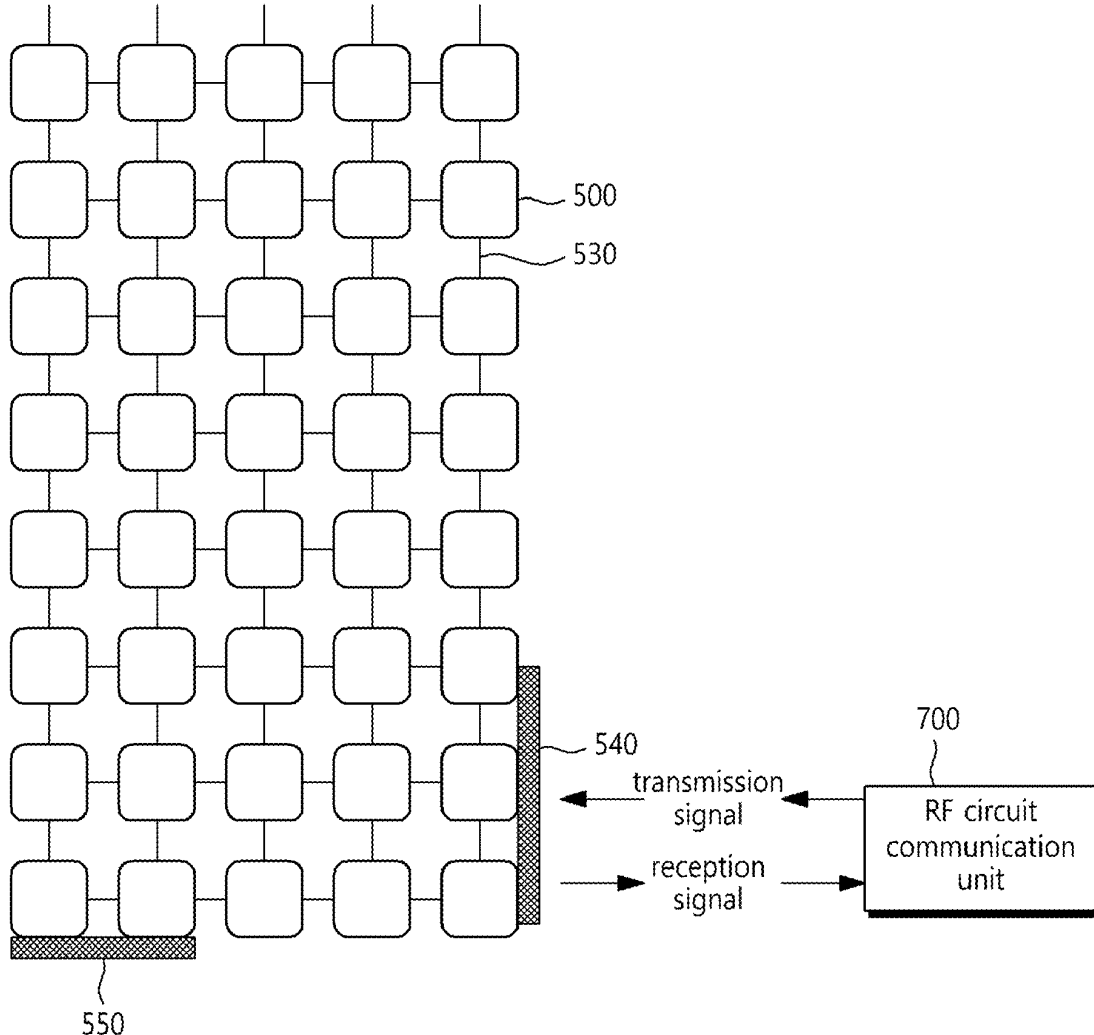



US 20250219290A1

(19) **United States**

(12) **Patent Application Publication**  
**Singh et al.**

(10) **Pub. No.: US 2025/0219290 A1**

(43) **Pub. Date: Jul. 3, 2025**

(54) **MULTIBAND REFLECTIVE SURFACE WITH BEAM STEERING AND BEAM SPLITTING FUNCTIONALITY**

(52) **U.S. Cl.**  
CPC ..... **H01Q 3/46** (2013.01); **H01Q 15/0033** (2013.01)

(71) Applicant: **Dell Products L.P.**, Round Rock, TX (US)

(57) **ABSTRACT**

(72) Inventors: **Tejinder Singh**, Kanata (CA); **Kan Wang**, Ottawa (CA); **Navjot Kaur Khaira**, Kanata (CA); **Morris Repeta**, Ottawa (CA)

The technology described herein is directed towards a multiband unit cell that is part of a reflective surface that can reflect different specific frequencies of impinging electromagnetic waves. The unit cells can have different phase profiles to facilitate beam steering and/or beam splitting functionality, independently for each specific frequency. The multiband unit cell can be a dual-band unit cell based on a straightforward unit-cell design, e.g., using diagonally arranged ring resonators as sub-cells of a supercell. Alternative design variations are also described to accommodate multi-frequency (greater than two frequency) applications. In one example implementation, the metasurface is constructed as a low-profile dual-band reflective surface with beam-steering and/or beam-splitting capabilities, e.g., utilizing only a single unit cell metal layer above a substrate. This enables precise control and manipulation of an antenna's radiation pattern, providing enhanced coverage for both frequency bands while keeping the fabrication/manufacturing costs relatively low.

(21) Appl. No.: **18/403,467**

(22) Filed: **Jan. 3, 2024**

**Publication Classification**

(51) **Int. Cl.**  
**H01Q 3/46** (2006.01)  
**H01Q 15/00** (2006.01)

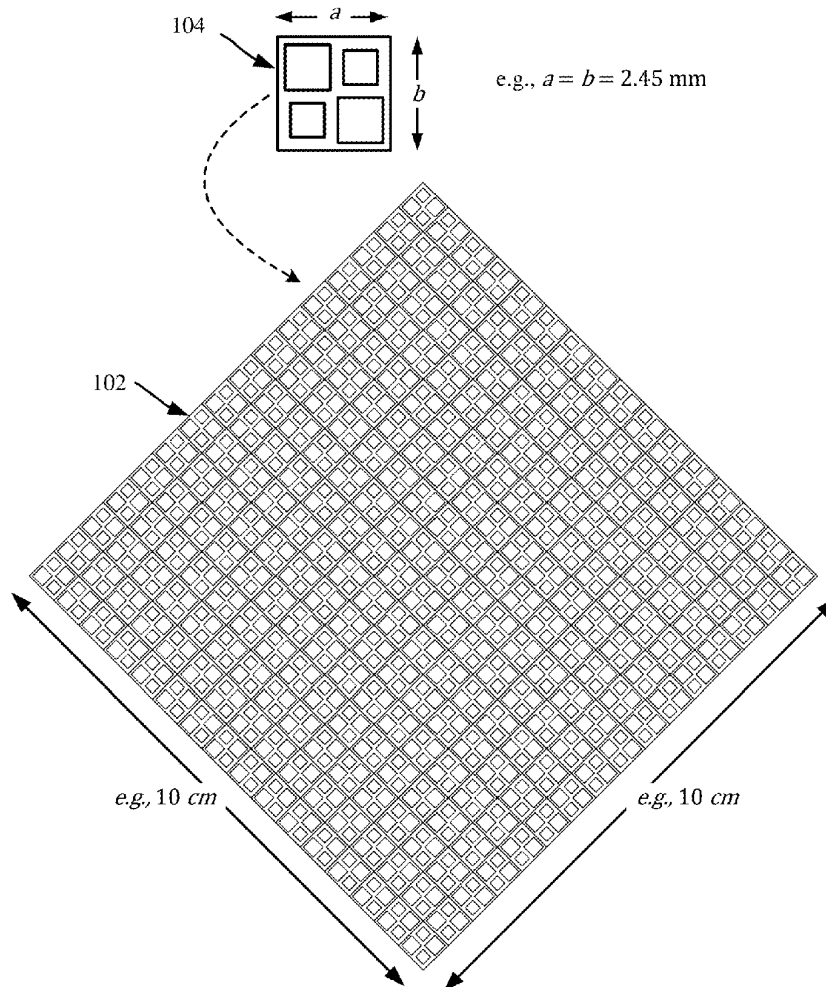



US 20250219291A1

(19) **United States**

(12) **Patent Application Publication**  
**SONG et al.**

(10) **Pub. No.: US 2025/0219291 A1**

(43) **Pub. Date: Jul. 3, 2025**

(54) **ANTENNA AND CONTROL DEVICE**

(52) **U.S. Cl.**

(71) Applicant: **AUTEL ROBOTICS CO., LTD.**,  
Nanshan District (CN)

CPC ..... **H01Q 5/307** (2015.01); **H01Q 1/42**  
(2013.01)

(72) Inventors: **Jianping SONG**, Nanshan District  
(CN); **Zhixiang LI**, Nanshan District  
(CN)

(57) **ABSTRACT**

(21) Appl. No.: **19/004,281**

(22) Filed: **Dec. 28, 2024**

(30) **Foreign Application Priority Data**

Dec. 29, 2023 (CN) ..... 202311865438.1

Disclosed are an antenna and a control device, which relate to the technical field of antennas. The antenna includes a housing and an antenna module, where the housing includes a radome and a reflecting bottom housing, and the radome and the reflecting bottom housing jointly form an accommodating cavity; and the antenna module is mounted in the accommodating cavity, the antenna module is configured to radiate an electromagnetic signal, and the reflecting bottom housing is configured to reflect the electromagnetic signal radiated by the antenna module, such that the electromagnetic signal radiates in a direction of the radome. Through the above method, a distance of radiating the electromagnetic signal by the antenna can be increased through embodiments of the disclosure.

**Publication Classification**

(51) **Int. Cl.**  
**H01Q 5/307** (2015.01)  
**H01Q 1/42** (2006.01)

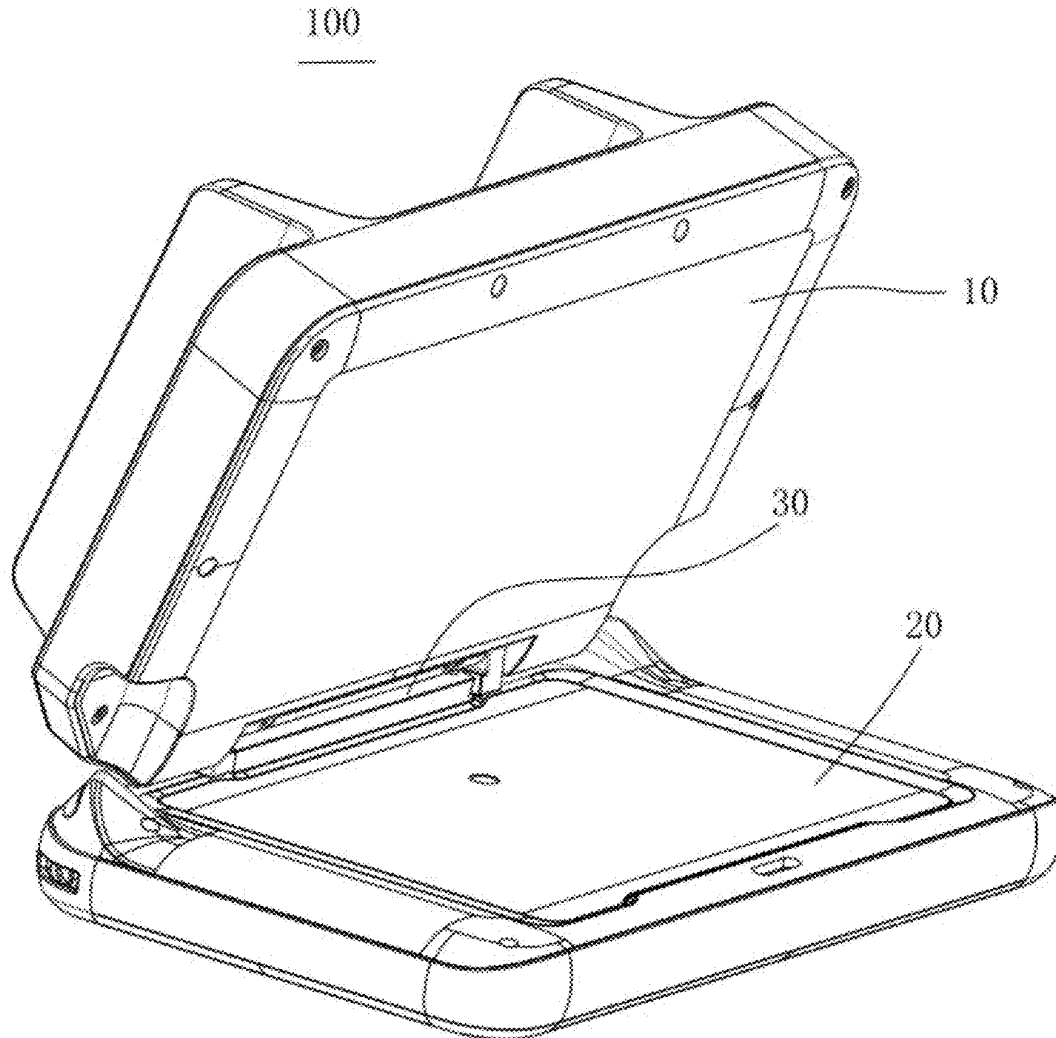



US 20250219292A1

(19) **United States**

(12) **Patent Application Publication**  
**CHANG et al.**

(10) **Pub. No.: US 2025/0219292 A1**

(43) **Pub. Date: Jul. 3, 2025**

(54) **DUAL-BAND DIPOLE ANTENNA AND ELECTRONIC DEVICE**

**Publication Classification**

(71) Applicant: **LUXSHARE PRECISION INDUSTRY COMPANY LIMITED, SHENZHEN (CN)**

(51) **Int. Cl.**  
**H01Q 5/48** (2015.01)  
**H01Q 5/50** (2015.01)

(72) Inventors: **Yao-Yuan CHANG, Taipei City (TW); Yu-Tsung WANG, Taipei City (TW); Wei-Hsin CHEN, Taipei City (TW)**

(52) **U.S. Cl.**  
CPC ..... **H01Q 5/48** (2015.01); **H01Q 5/50** (2015.01)

(73) Assignee: **LUXSHARE PRECISION INDUSTRY COMPANY LIMITED, SHENZHEN (CN)**

(57) **ABSTRACT**

Disclosed is a dual-band dipole antenna including a dielectric carrier with a first surface, a first radiator, a second radiator, a coupled radiator, a coaxial cable and a balun line. The first radiator and the second radiator in opposite areas of the first surface have different structural shapes. The coupled radiator on the first surface extends from the second radiator toward the first radiator. There is a coupling slot between the coupled radiator and the first radiator. An inner conductor and an outer conductor of the coaxial cable are electrically connected to the second radiator and the first radiator respectively. The balun line disposed on the first surface has a serpentine structure, and is connected to the first radiator and the second radiator. The first radiator, the second radiator and the coupled radiator are configured to generate a first resonance mode, a second resonance mode and a third resonance mode.

(21) Appl. No.: **18/829,851**

(22) Filed: **Sep. 10, 2024**

(30) **Foreign Application Priority Data**

Dec. 27, 2023 (CN) ..... 202311836081.4

1

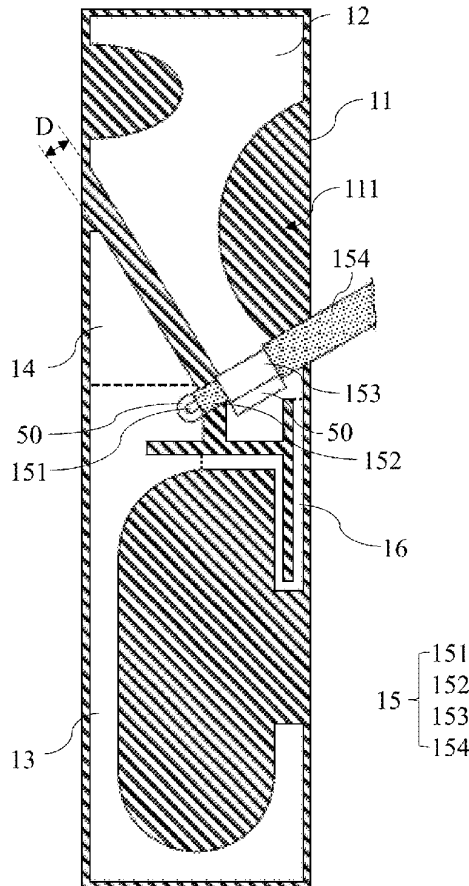



US 20250219293A1

(19) **United States**

(12) **Patent Application Publication**  
**YEOM et al.**

(10) **Pub. No.: US 2025/0219293 A1**

(43) **Pub. Date: Jul. 3, 2025**

(54) **ELECTRONIC DEVICE COMPRISING ANTENNA**

*H01Q 1/38* (2006.01)

*H01Q 5/307* (2015.01)

(71) Applicant: **Samsung Electronics Co., Ltd.**,  
Suwon-si (KR)

(52) **U.S. Cl.**

CPC ..... *H01Q 7/00* (2013.01); *H01Q 1/24*

(2013.01); *H01Q 1/38* (2013.01); *H01Q 5/307*

(2015.01)

(72) Inventors: **Junghwan YEOM**, Suwon-si (KR); **Jin KIM**,  
Suwon-si (KR); **Jongoh LIM**, Suwon-si (KR)

(57)

**ABSTRACT**

(21) Appl. No.: **19/082,866**

(22) Filed: **Mar. 18, 2025**

**Related U.S. Application Data**

(63) Continuation of application No. PCT/KR2023/012963, filed on Aug. 31, 2023.

(30) **Foreign Application Priority Data**

Oct. 5, 2022 (KR) ..... 10-2022-0126825

Dec. 1, 2022 (KR) ..... 10-2022-0166069

**Publication Classification**

(51) **Int. Cl.**

*H01Q 7/00* (2006.01)

*H01Q 1/24* (2006.01)

An electronic device may include a substrate and a wireless communication circuit. The substrate may include a housing, a ground area, a first conductive pattern, a second conductive pattern, and a third conductive pattern. The housing may include a conductive portion. The first conductive pattern is electrically connected to the conductive portion. The second conductive pattern is electrically connected to the ground area. The first conductive pattern electrically connects the conductive portion to the ground area. The wireless communication circuit is configured to supply power to the conductive portion through the first conductive pattern. The second conductive pattern may include a closed loop shape. The second conductive pattern is at least partially located between at least the first conductive pattern and the third conductive pattern.

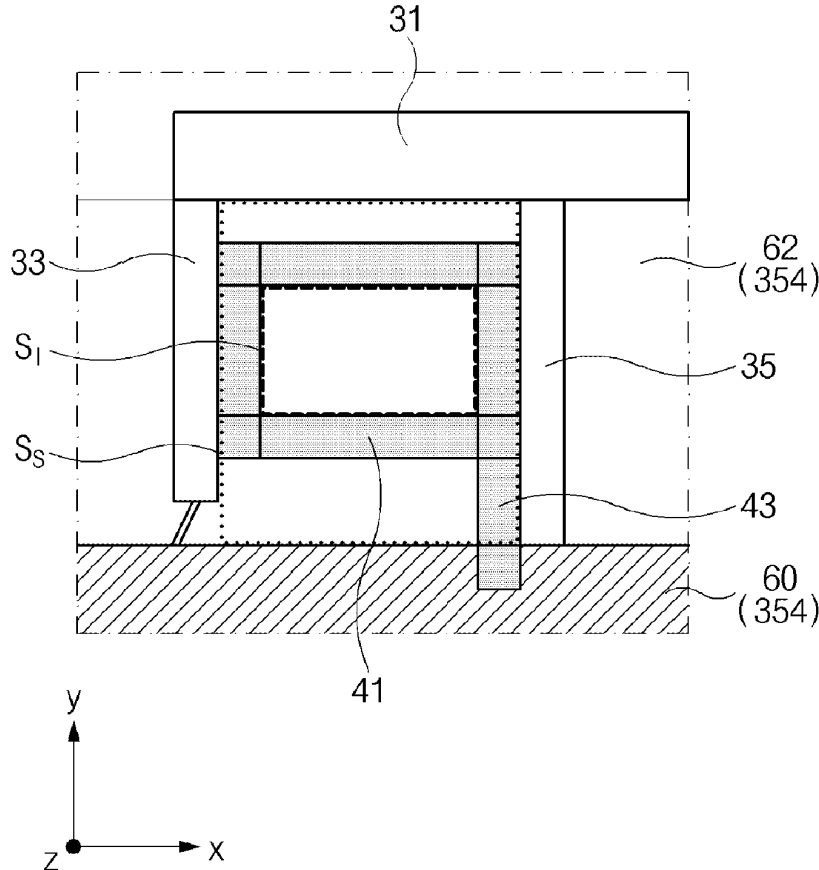



US 20250219296A1

(19) **United States**

(12) **Patent Application Publication**  
YIN et al.

(10) **Pub. No.: US 2025/0219296 A1**

(43) **Pub. Date: Jul. 3, 2025**

(54) **TRANSMISSION LINE, FEED NETWORK,  
AND ANTENNA APPARATUS**

(71) Applicant: **HUAWEI TECHNOLOGIES CO.,  
LTD.**, Shenzhen (CN)

(72) Inventors: **Minghua YIN**, Dongguan (CN);  
**Zhongwei PENG**, Dongguan (CN);  
**Junlang WU**, Dongguan (CN); **Wei  
HAO**, Dongguan (CN); **Wen WU**,  
Shenzhen (CN)

(21) Appl. No.: **19/083,899**

(22) Filed: **Mar. 19, 2025**

**Related U.S. Application Data**

(63) Continuation of application No. PCT/CN2023/  
118920, filed on Sep. 14, 2023.

(30) **Foreign Application Priority Data**

Sep. 20, 2022 (CN) ..... 202211144650.4

**Publication Classification**

(51) **Int. Cl.**  
**H01Q 19/10** (2006.01)  
**H01Q 9/28** (2006.01)  
**H01Q 15/18** (2006.01)  
(52) **U.S. Cl.**  
CPC ..... **H01Q 19/106** (2013.01); **H01Q 9/28**  
(2013.01); **H01Q 15/18** (2013.01)

(57) **ABSTRACT**

Embodiments of this application provide a transmission line, a feed network, and an antenna apparatus. The transmission line is used for a radio frequency device. The transmission line includes a reflector, an insulation support, and a transmission structure. The transmission structure includes at least two side walls. The transmission structure is disposed on a surface of the insulation support, an included angle between two adjacent side walls of the transmission structure is greater than zero, and different side walls of the transmission structure are located on different surfaces of the insulation support. At least one surface of the transmission structure is disposed opposite to a part of a structure of the reflector, and a gap exists between the at least one surface of the transmission structure and the reflector. The transmission line has a small signal loss and occupies a small space.

1221

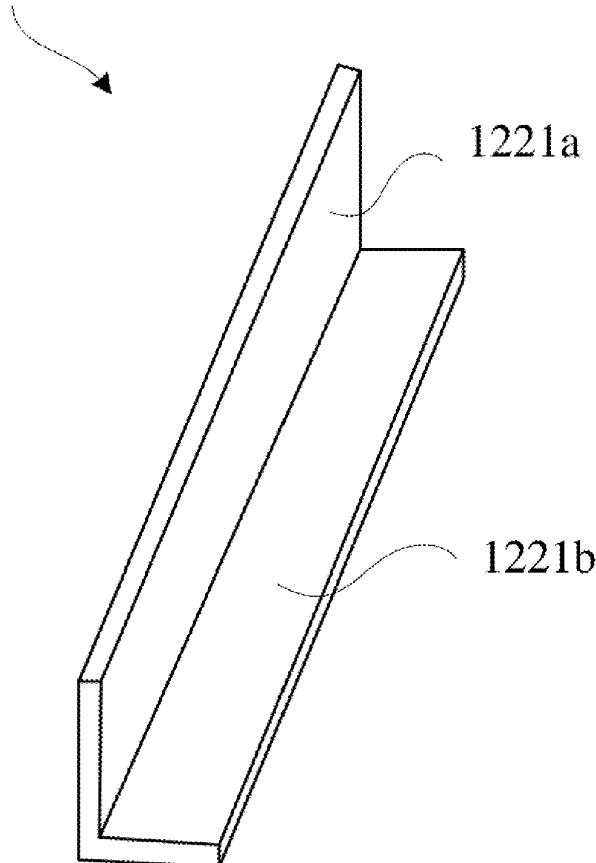



US 20250219297A1

(19) **United States**

(12) **Patent Application Publication**  
LV et al.

(10) **Pub. No.: US 2025/0219297 A1**

(43) **Pub. Date: Jul. 3, 2025**

(54) **ANTENNA APPARATUS AND COMMUNICATION DEVICE**

(71) Applicant: **HUAWEI TECHNOLOGIES CO., LTD.**, Shenzhen (CN)  
(72) Inventors: **Jinsong LV**, Shanghai (CN); **Tao PU**, Shanghai (CN); **Jinju WANG**, Dongguan (CN); **Jia LV**, Shanghai (CN); **Weihong XIAO**, Dongguan (CN)

(21) Appl. No.: **19/083,737**

(22) Filed: **Mar. 19, 2025**

**Related U.S. Application Data**

(63) Continuation of application No. PCT/CN2023/117479, filed on Sep. 7, 2023.

**Foreign Application Priority Data**

Sep. 20, 2022 (CN) ..... 202211145858.8

**Publication Classification**

(51) **Int. Cl.**  
*H01Q 21/00* (2006.01)  
*H01Q 1/24* (2006.01)  
*H01Q 3/46* (2006.01)  
*H01Q 15/00* (2006.01)  
*H01Q 15/08* (2006.01)  
(52) **U.S. Cl.**  
CPC ..... *H01Q 21/0031* (2013.01); *H01Q 3/46* (2013.01); *H01Q 15/0086* (2013.01); *H01Q 15/08* (2013.01); *H01Q 1/246* (2013.01)

(57) **ABSTRACT**

Embodiments of this application provide an antenna apparatus and a communication device. The antenna apparatus includes a lens unit and a plurality of radiating elements. The plurality of radiating elements are arranged in an array to form an array structure. There are a plurality of side regions on a circumferential outer side of the array structure, and the lens unit is disposed in at least one of the plurality of side regions, so that an electromagnetic wave signal radiated from a side surface of the radiating element can be radiated after passing through the lens unit. Correspondingly, an electromagnetic wave signal may also be received by the radiating element after passing through the lens unit.

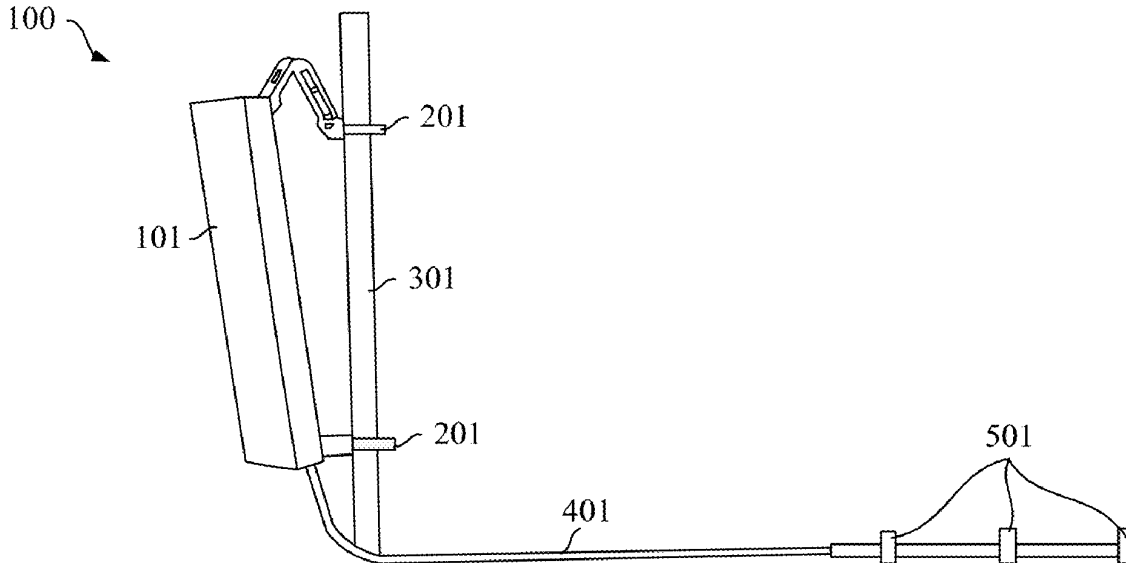



US 20250224769A1

(19) **United States**

(12) **Patent Application Publication**  
**CHEN et al.**

(10) **Pub. No.: US 2025/0224769 A1**

(43) **Pub. Date: Jul. 10, 2025**

(54) **TABLET DEVICE**

(52) **U.S. Cl.**

(71) Applicant: **Getac Technology Corporation**, New Taipei City (TW)

CPC ..... **G06F 1/1637** (2013.01); **G06F 1/1698** (2013.01)

(72) Inventors: **PO-YEN CHEN**, Taipei City (TW);  
**YIN-CHENG TSAI**, Taipei City (TW)

(57) **ABSTRACT**

(21) Appl. No.: **18/830,927**

A tablet device includes: a case having a top surface and a bottom surface, where a side button frame is provided on one side edge of the top surface; a metal support plate arranged in the case, where a hollow part is provided on one side edge of the metal support plate that corresponds to the side button frame, such that the hollow part forms a space in the case; a support frame arranged in the space; a side button sensor arranged in the side button frame; a side button control board arranged on the side edge of the metal support plate; and an antenna module arranged in the space; where the side button sensor, the support frame, and the antenna module are substantially overlapped with one another.

(22) Filed: **Sep. 11, 2024**

(30) **Foreign Application Priority Data**

Jan. 4, 2024 (CN) ..... 202410012881.2

**Publication Classification**

(51) **Int. Cl.**  
**G06F 1/16** (2006.01)

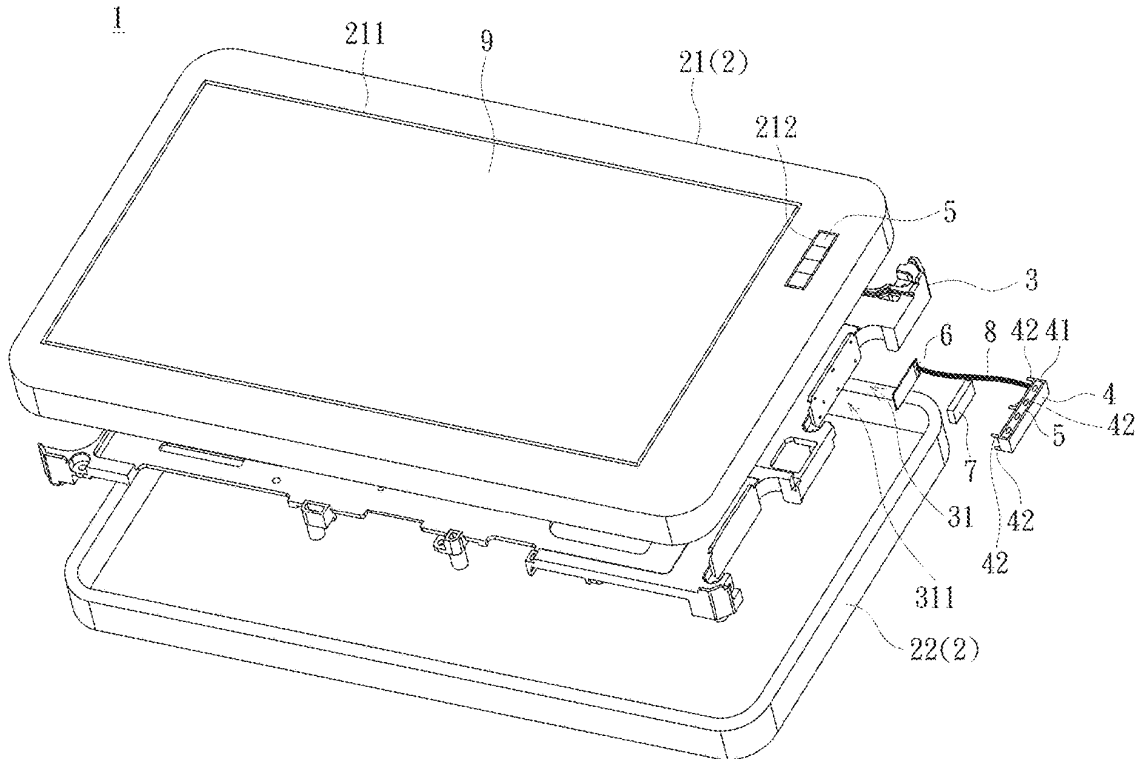



US 20250224775A1

(19) **United States**

(12) **Patent Application Publication**  
**HSIEH**

(10) **Pub. No.: US 2025/0224775 A1**

(43) **Pub. Date: Jul. 10, 2025**

(54) **ELECTRONIC DEVICE**

(71) Applicant: **Getac Technology Corporation**, New Taipei City (TW)

(72) Inventor: **CHENG YU HSIEH**, Taipei City (TW)

(21) Appl. No.: **18/939,749**

(22) Filed: **Nov. 7, 2024**

(30) **Foreign Application Priority Data**

Jan. 8, 2024 (CN) ..... 202410023088.2

**Publication Classification**

(51) **Int. Cl.**  
**G06F 1/16** (2006.01)  
**H01Q 1/22** (2006.01)

(52) **U.S. Cl.**

CPC ..... **G06F 1/1658** (2013.01); **G06F 1/1681** (2013.01); **H01Q 1/2266** (2013.01)

(57) **ABSTRACT**

An electronic device includes a first housing for disposing a display screen, and a second housing for disposing a system circuit board, wherein a first side of the second housing is directly connected to a first side of the first housing through a rotating pivot; wherein an antenna circuit board is disposed on a second side of the first housing relative to the rotating pivot, the antenna circuit board has a radiating portion and a first grounding portion, and the radiating portion includes an antenna segment; wherein a second side of the second housing relative to the rotating pivot has a conductor layer, and the conductor layer has a coupling portion and a second grounding portion; when the electronic device is in the tablet mode, the conductor layer overlaps the antenna circuit board. In this way, the impedance mismatch and frequency offset of the antenna in tablet mode are improved.

1

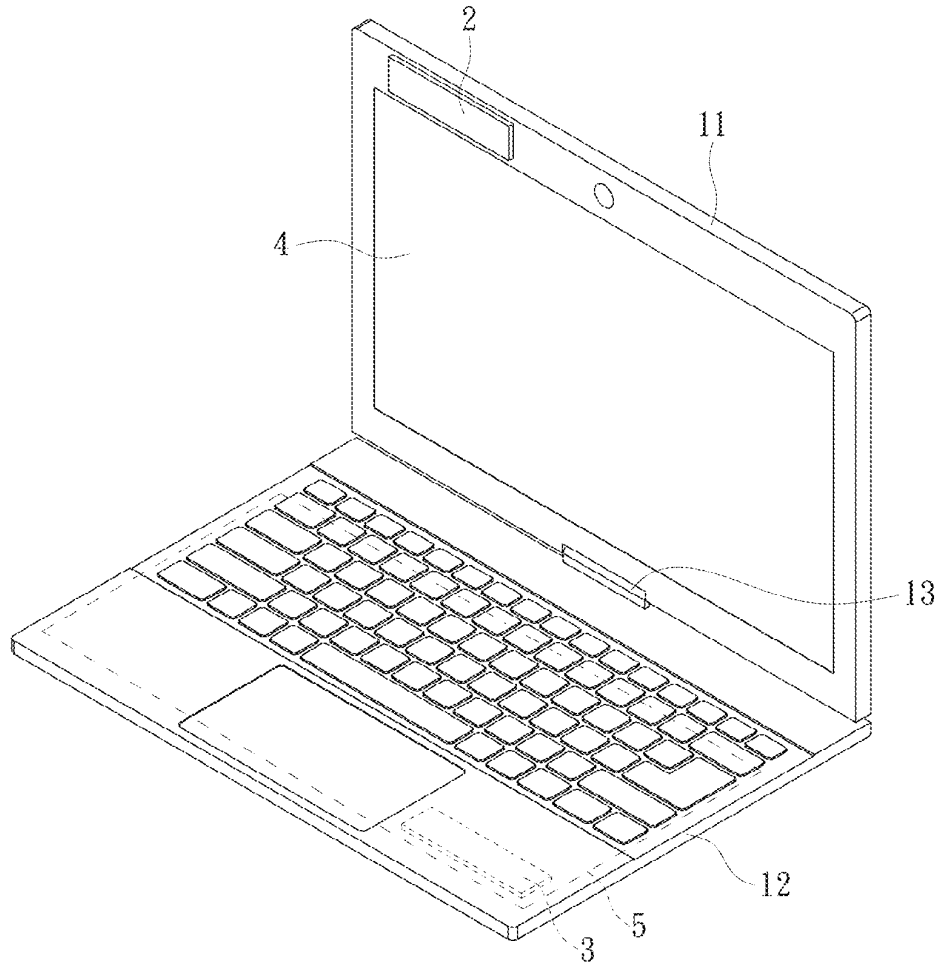



US 20250226567A1

(19) **United States**

(12) **Patent Application Publication**  
**Zhang et al.**

(10) **Pub. No.: US 2025/0226567 A1**  
(43) **Pub. Date: Jul. 10, 2025**

- (54) **DISPLAY APPARATUS**
- (71) Applicants: **Beijing BOE Technology Development Co., Ltd.**, Beijing (CN); **BOE Technology Group Co., Ltd.**, Beijing (CN)
- (72) Inventors: **Yafei Zhang**, Beijing (CN); **Dongdong Zhang**, Beijing (CN); **Mengwen Jia**, Beijing (CN); **Xudong Zhang**, Beijing (CN); **Feng Qu**, Beijing (CN)
- (73) Assignees: **Beijing BOE Technology Development Co., Ltd.**, Beijing (CN); **BOE Technology Group Co., Ltd.**, Beijing (CN)

- H01Q 1/48* (2006.01)
- H01Q 9/04* (2006.01)
- H10K 59/40* (2023.01)
- H10K 59/80* (2023.01)
- H10K 59/82* (2023.01)
- (52) **U.S. Cl.**
- CPC ..... *H01Q 1/22* (2013.01); *G06F 3/0412* (2013.01); *G09G 3/3225* (2013.01); *H01Q 1/48* (2013.01); *H01Q 9/045* (2013.01); *H10K 59/40* (2023.02); *H10K 59/82* (2023.02); *H10K 59/8791* (2023.02); *H10K 59/8794* (2023.02); *G06F 3/0446* (2019.05); *G09G 2300/0413* (2013.01); *G09G 2300/0819* (2013.01); *G09G 2300/0842* (2013.01); *G09G 2300/0861* (2013.01); *G09G 2354/00* (2013.01)

- (21) Appl. No.: **18/689,810**
- (22) PCT Filed: **Jun. 21, 2023**
- (86) PCT No.: **PCT/CN2023/101566**
- § 371 (c)(1),  
(2) Date: **Mar. 6, 2024**

(57) **ABSTRACT**

A display apparatus is provided. The display apparatus includes a display area and a peripheral area. The display area includes a first display sub-area and a second display sub-area. The second display sub-area has a subpixel distribution density lower than a subpixel distribution density of the first display sub-area. The display apparatus further includes an antenna, a touch structure, and a display module. The antenna includes a radiating plate, a feed line, a ground plate, and a slot extending through at least the ground plate. The radiating plate, the feed line, the ground plate, and the slot are at least partially in the second display sub-area and outside the first display sub-area.

**Publication Classification**

- (51) **Int. Cl.**
- H01Q 1/22* (2006.01)
- G06F 3/041* (2006.01)
- G06F 3/044* (2006.01)
- G09G 3/3225* (2016.01)

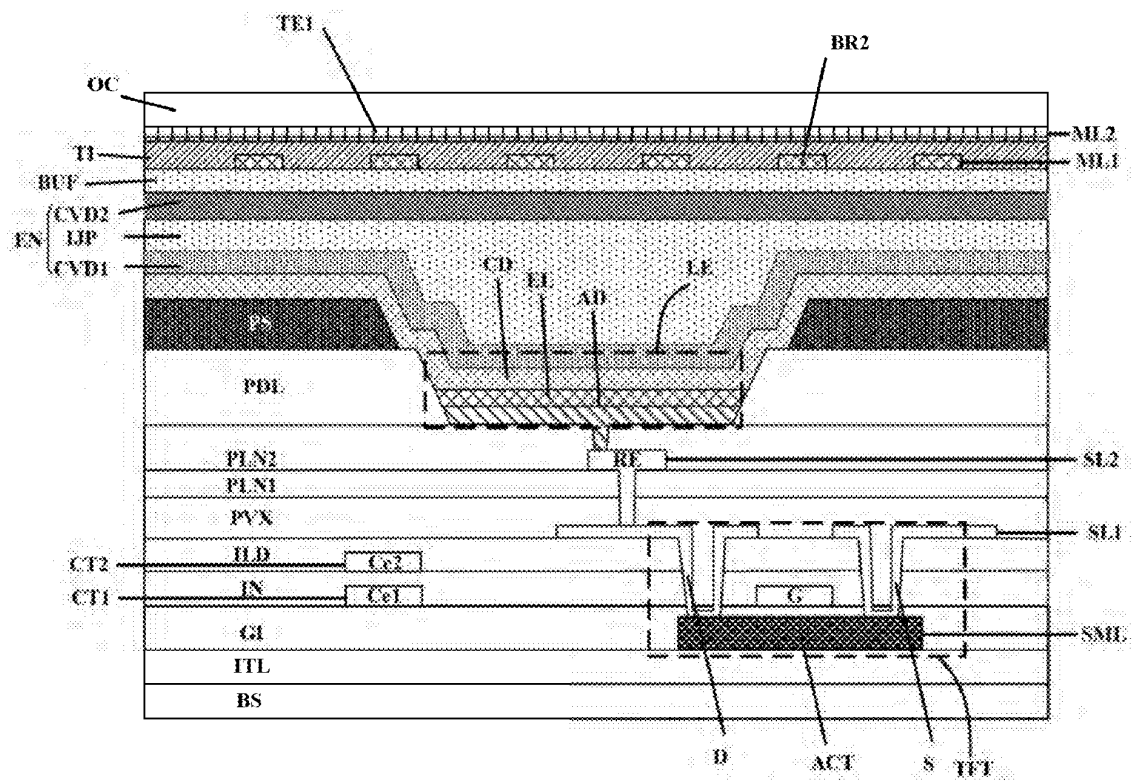



US 20250226568A1

(19) **United States**

(12) **Patent Application Publication** (10) **Pub. No.: US 2025/0226568 A1**

**YUN et al.**

(43) **Pub. Date: Jul. 10, 2025**

(54) **ELECTRONIC DEVICE COMPRISING ANTENNA**

(71) Applicant: **Samsung Electronics Co., Ltd.**, Suwon-si (KR)

(72) Inventors: **Himchan YUN**, Suwon-si (KR); **Sungkoo PARK**, Suwon-si (KR); **Kyungjae LEE**, Suwon-si (KR); **Kookjoo LEE**, Suwon-si (KR); **Donguk CHOI**, Suwon-si (KR); **Soonho HWANG**, Suwon-si (KR); **Seunghwan KIM**, Suwon-si (KR); **Jaebong CHUN**, Suwon-si (KR)

(21) Appl. No.: **19/091,092**

(22) Filed: **Mar. 26, 2025**

**Related U.S. Application Data**

(63) Continuation of application No. PCT/KR2023/014713, filed on Sep. 25, 2023.

(30) **Foreign Application Priority Data**

Sep. 26, 2022 (KR) ..... 10-2022-0122005  
Nov. 1, 2022 (KR) ..... 10-2022-0144070

**Publication Classification**

(51) **Int. Cl.**  
**H01Q 1/22** (2006.01)  
**G06F 1/16** (2006.01)  
(52) **U.S. Cl.**  
CPC ..... **H01Q 1/2266** (2013.01); **G06F 1/1652** (2013.01)

(57) **ABSTRACT**

An electronic device is provided. The electronic device includes a first housing, a second housing, and a communication circuit. The communication circuit is configured to communicate with an external electronic device by using an electromagnetic field generated in a first slot of the first housing and a second slot of the second housing on the basis of powering a first conductive portion of the first housing in a folded state.

101

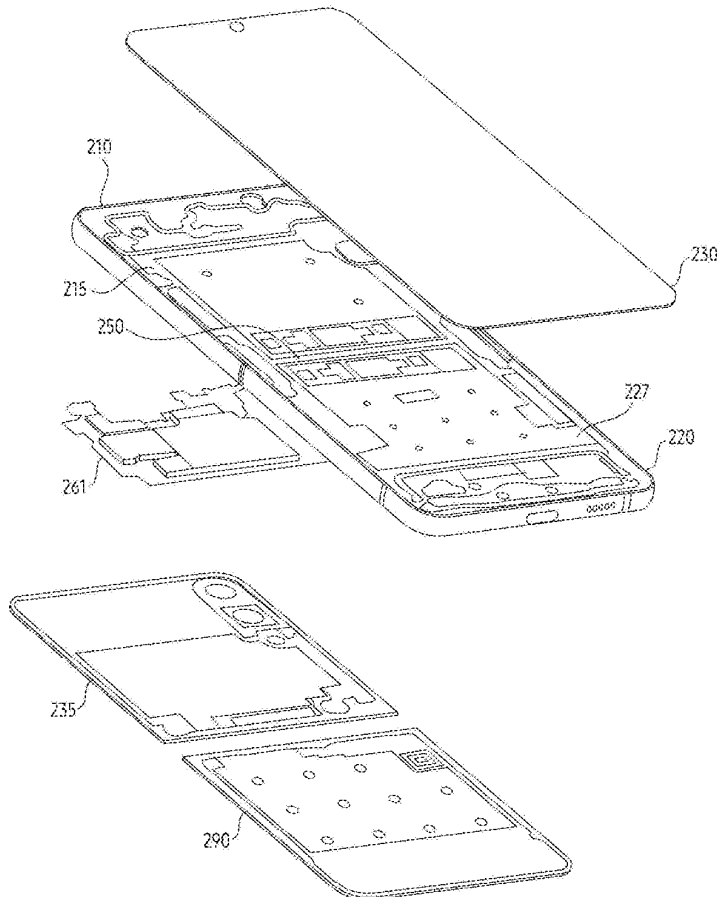



US 20250226579A1

(19) **United States**

(12) **Patent Application Publication**  
**CHAN**

(10) **Pub. No.: US 2025/0226579 A1**

(43) **Pub. Date: Jul. 10, 2025**

(54) **HYBRID ANTENNA STRUCTURE**

*H01Q 9/04* (2006.01)

*H01Q 13/10* (2006.01)

(71) Applicant: **Quanta Computer Inc.**, Taoyuan City (TW)

(52) **U.S. Cl.**

CPC ..... *H01Q 5/35* (2015.01); *H01Q 5/20* (2015.01); *H01Q 9/0421* (2013.01); *H01Q 13/10* (2013.01)

(72) Inventor: **Ming-Che CHAN**, Taoyuan City (TW)

(21) Appl. No.: **18/435,074**

(57)

**ABSTRACT**

(22) Filed: **Feb. 7, 2024**

A hybrid antenna structure includes a metal cavity, a dielectric substrate, and an antenna pattern. The metal cavity has a slot. The dielectric substrate is embedded in the slot of the metal cavity. The dielectric substrate has a first surface and a second surface which are opposite to each other. The antenna pattern is distributed over the first surface and the second surface of the dielectric substrate. The slot of the metal cavity and the antenna pattern are excited to generate a first frequency band, a second frequency band, and a third frequency band.

(30) **Foreign Application Priority Data**

Jan. 8, 2024 (TW) ..... 113200233

**Publication Classification**

(51) **Int. Cl.**

*H01Q 5/35* (2015.01)

*H01Q 5/20* (2015.01)

100

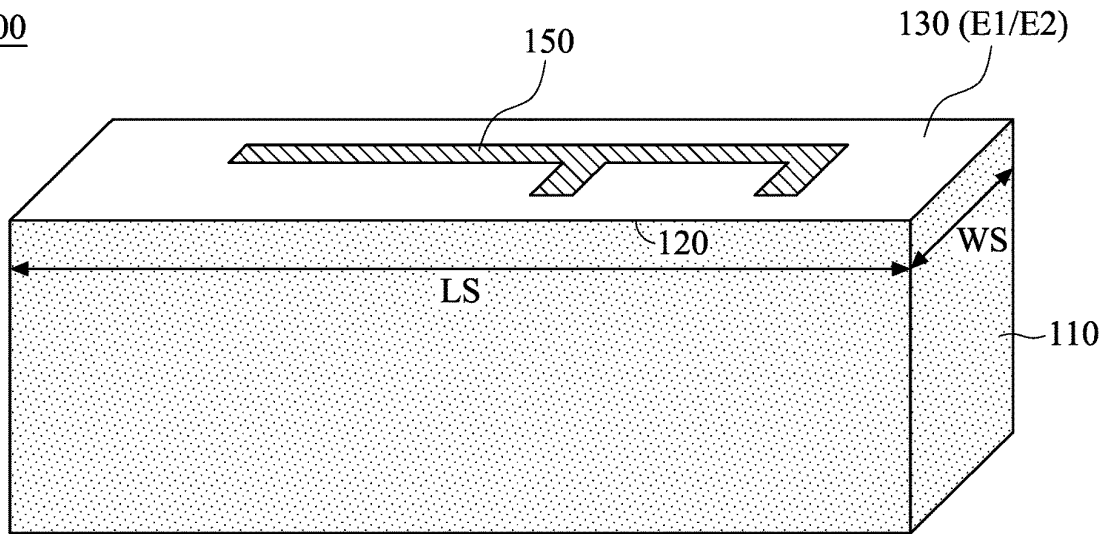



US 20250226582A1

(19) **United States**

(12) **Patent Application Publication**  
**ICHIKAWA et al.**

(10) **Pub. No.: US 2025/0226582 A1**

(43) **Pub. Date: Jul. 10, 2025**

(54) **ANTENNA MODULE**

**Publication Classification**

(71) Applicant: **Murata Manufacturing Co., Ltd.**,  
Nagaokakyo-shi (JP)

(51) **Int. Cl.**  
**H01Q 9/04** (2006.01)  
**H01Q 1/38** (2006.01)

(72) Inventors: **Keiichi ICHIKAWA**, Nagaokakyo-shi  
(JP); **Kosuke NISHIO**, Nagaokakyo-shi  
(JP)

(52) **U.S. Cl.**  
CPC ..... **H01Q 9/0407** (2013.01); **H01Q 1/38**  
(2013.01)

(73) Assignee: **Murata Manufacturing Co., Ltd.**,  
Nagaokakyo-shi (JP)

(57) **ABSTRACT**

An antenna structure has a second positive main surface that is in contact with a first negative main surface. At least one first ground conductor layer is positioned in a positive direction along a Z-axis from a signal conductor layer. The at least one first ground conductor layer is not positioned at a second positive main surface. A first substrate area in which a first substrate is disposed has an unoccupied-by-ground-conductor-layer area in which the at least one first ground conductor layer is not disposed when viewed in a negative direction along the Z-axis. The signal conductor layer overlaps the unoccupied-by-ground-conductor-layer area when viewed in the negative direction along the Z-axis. At a portion in the unoccupied-by-ground-conductor-layer area in the positive direction along the Z-axis from the signal conductor layer, no conductor other than a radiating conductor layer covers an entirety of the unoccupied-by-ground-conductor-layer area.

(21) Appl. No.: **19/091,840**

(22) Filed: **Mar. 27, 2025**

**Related U.S. Application Data**

(63) Continuation of application No. PCT/JP2023/  
032710, filed on Sep. 7, 2023.

(30) **Foreign Application Priority Data**

Oct. 11, 2022 (JP) ..... 2022-163056

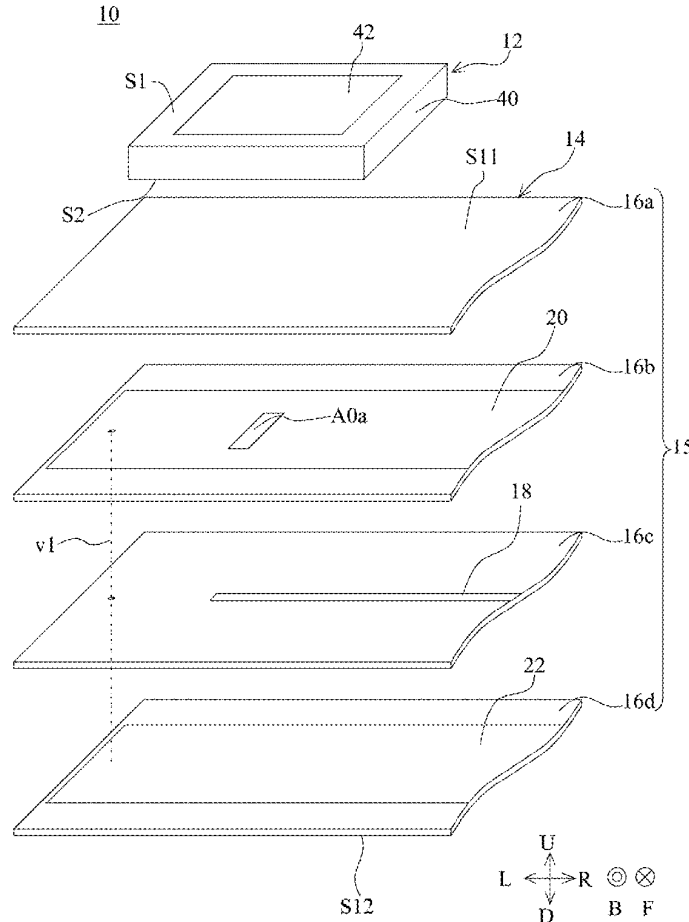



US 20250226584A1

(19) **United States**

(12) **Patent Application Publication**  
**Fang et al.**

(10) **Pub. No.: US 2025/0226584 A1**

(43) **Pub. Date: Jul. 10, 2025**

(54) **ANTENNA**

**Publication Classification**

(71) Applicants: **Beijing BOE Technology Development Co., Ltd.**, Beijing (CN); **BOE Technology Group Co., Ltd.**, Beijing (CN)

(51) **Int. Cl.**  
*H01Q 9/04* (2006.01)  
*H01Q 1/48* (2006.01)  
*H01Q 3/36* (2006.01)

(72) Inventors: **Jia Fang**, Beijing (CN); **Feng Qu**, Beijing (CN); **Ying Ding**, Beijing (CN)

(52) **U.S. Cl.**  
CPC ..... *H01Q 9/045* (2013.01); *H01Q 1/48* (2013.01); *H01Q 3/36* (2013.01); *H01Q 9/0414* (2013.01)

(73) Assignees: **Beijing BOE Technology Development Co., Ltd.**, Beijing (CN); **BOE Technology Group Co., Ltd.**, Beijing (CN)

(57) **ABSTRACT**

An antenna is provided. The antenna includes a feed line structure; a first low dielectric constant layer on the feed line structure; a first flexible layer on a side of the first low dielectric constant layer away from the feed line structure; a phase shifter on a side of the first flexible layer away from the first low dielectric constant layer; a first ground plate on a side of the phase shifter away from the first flexible layer; and a radiating plate on a side of the first ground plate away from the phase shifter. The first low dielectric constant layer has a dielectric constant in a range of 1.5 to 3. The first flexible layer has a Flexural modulus in a range of 0.01 to 10.0.

(21) Appl. No.: **18/689,817**

(22) PCT Filed: **Jul. 11, 2023**

(86) PCT No.: **PCT/CN2023/106795**

§ 371 (c)(1),

(2) Date: **Mar. 6, 2024**

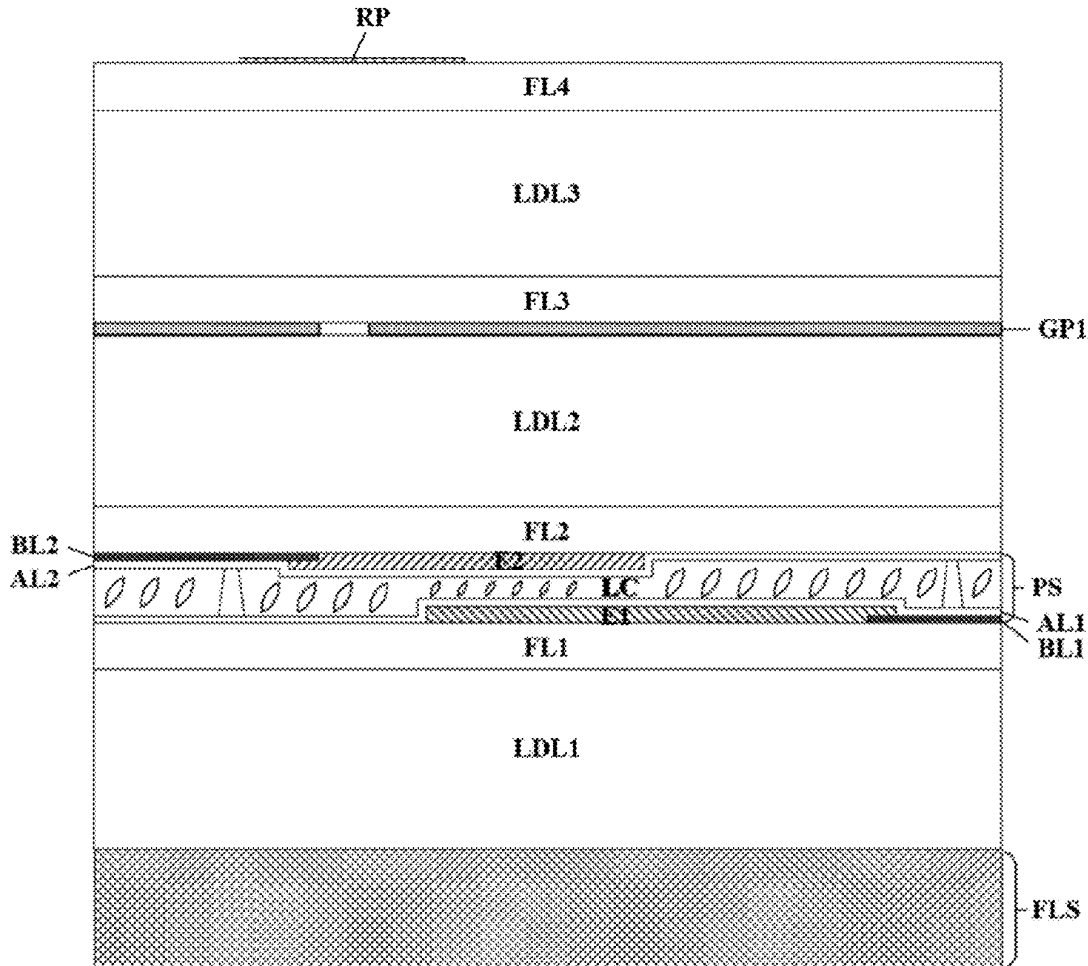



US 20250226589A1

(19) **United States**

(12) **Patent Application Publication**  
**CHEN et al.**

(10) **Pub. No.: US 2025/0226589 A1**

(43) **Pub. Date: Jul. 10, 2025**

(54) **POLARIZATION CONVERSION  
STRUCTURE AND ANTENNA**

(52) **U.S. Cl.**  
CPC ..... **H01Q 15/242** (2013.01)

(71) Applicant: **BOE Technology Group Co., Ltd.,  
Beijing (CN)**

(57) **ABSTRACT**

(72) Inventors: **Shaopeng CHEN, Beijing (CN); Feng  
QU, Beijing (CN)**

Provided are a polarization conversion structure and an antenna. The polarization conversion structure includes a ground structure layer (11), a first dielectric substrate (21) and a radiation structure layer (300) which are stacked in a direction perpendicular to a plane where the polarization conversion structure is located. The radiation structure layer (300) includes at least one radiation unit (30), the radiation element (30) includes a radiation structure (31), and the radiation structure (31) is arranged symmetrically with respect to a first centerline, wherein the first centerline is a centerline of the radiation structure (31) extending in a fourth direction on a plane parallel to the polarization conversion structure. Orthographic projections of the radiation unit (30) and the ground structure layer (11) on the first dielectric substrate (21) are at least partially overlapped.

(21) Appl. No.: **18/699,597**

(22) PCT Filed: **Aug. 3, 2023**

(86) PCT No.: **PCT/CN2023/111062**

§ 371 (c)(1),

(2) Date: **Apr. 9, 2024**

**Publication Classification**

(51) **Int. Cl.**  
**H01Q 15/24** (2006.01)

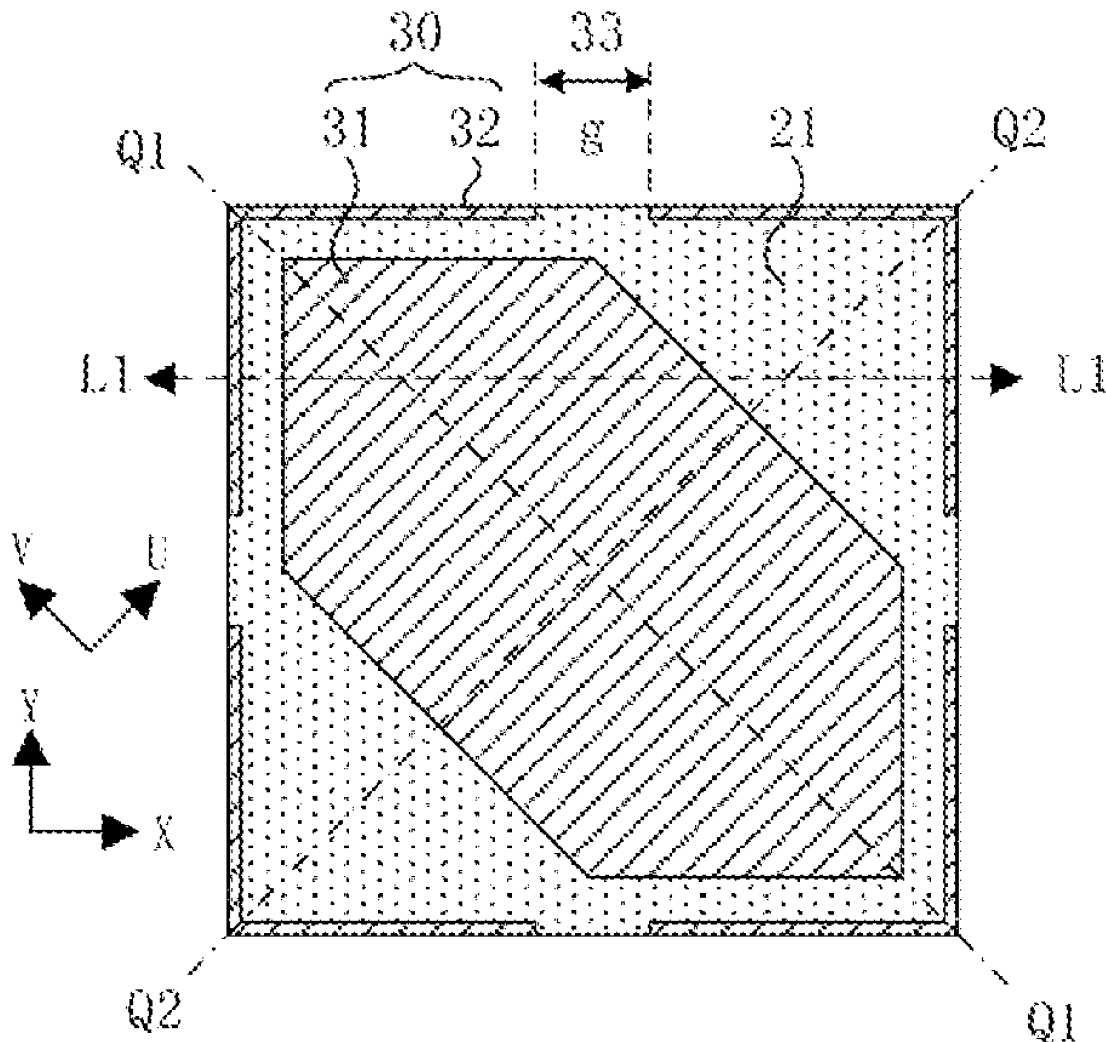



US 20250226591A1

(19) **United States**

(12) **Patent Application Publication**  
**HILL et al.**

(10) **Pub. No.: US 2025/0226591 A1**

(43) **Pub. Date: Jul. 10, 2025**

(54) **HIGH MAST WIRELESS APPARATUS TO PROVIDE WI-FI AND HIGH SPEED BACKHAUL SERVICES**

*H04B 7/0413* (2017.01)  
*H04W 88/08* (2009.01)

(52) **U.S. Cl.**  
CPC ..... *H01Q 21/065* (2013.01); *H04B 7/0413* (2013.01); *H01Q 1/1242* (2013.01); *H04W 88/08* (2013.01)

(71) Applicant: **BUCKEYE MOUNTAIN, INC.**,  
Akron, OH (US)

(72) Inventors: **Steve HILL**, Akron, OH (US); **Greg DUNNELL**, Akron, OH (US)

(21) Appl. No.: **19/014,133**

(22) Filed: **Jan. 8, 2025**

**Related U.S. Application Data**

(63) Continuation-in-part of application No. 17/835,181, filed on Jun. 8, 2022.

(60) Provisional application No. 63/220,879, filed on Jul. 12, 2021.

**Publication Classification**

(51) **Int. Cl.**  
*H01Q 21/06* (2006.01)  
*H01Q 1/12* (2006.01)

(57) **ABSTRACT**

A communications apparatus to be installed on high mast lighting systems or other vertical assets with significant above ground projections. The apparatus is designed to mount to existing light ring spokes or other existing mounting structures. The system is powered during nighttime hours by grid power and during daylight hours by internal battery storage. A uniquely-oriented directional dual polarity MIMO antenna adapted for high mast mounting supports communications with mobile vehicles using MIMO emissions in a North/South and East/West polarization. Mobile vehicle clients may then use dual polarized antennas including skyward-looking radiation patterns with major lobes that are oriented directly up towards the sky.

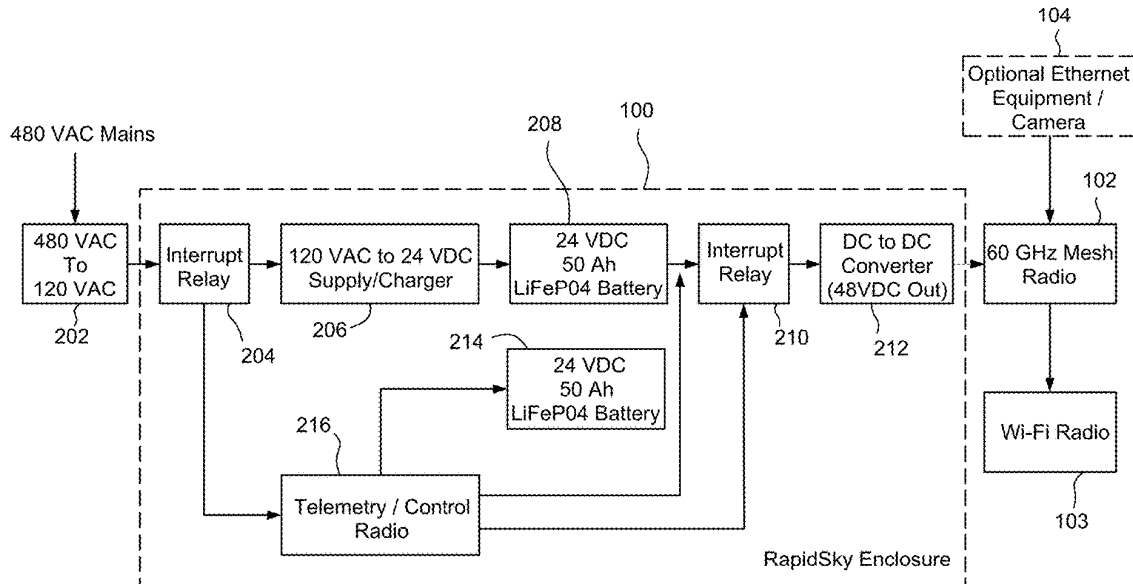



US 20250226593A1

(19) **United States**

(12) **Patent Application Publication**  
TSUKAHARA et al.

(10) **Pub. No.: US 2025/0226593 A1**

(43) **Pub. Date: Jul. 10, 2025**

(54) **ARRAY ANTENNA STRUCTURE AND  
ARRAY ANTENNA MODULE**

**Publication Classification**

(71) Applicant: **Panasonic Intellectual Property  
Management Co., Ltd.**, Osaka (JP)

(51) **Int. Cl.**  
**H01Q 21/06** (2006.01)

(72) Inventors: **NORIHITO TSUKAHARA**, Kyoto  
(JP); **MASATO MORI**, Hyogo (JP);  
**TAKAYUKI SOTOYAMA**, Kanagawa  
(JP); **NAOKI ADACHI**, Kanagawa  
(JP)

(52) **U.S. Cl.**  
CPC ..... **H01Q 21/065** (2013.01)

(21) Appl. No.: **19/093,334**

(57) **ABSTRACT**

(22) Filed: **Mar. 28, 2025**

Provided is an array antenna structure including m antenna structures disposed on an XY plane where m represents a number equal to or greater than 2. Each of the m antenna structures includes an antenna board, a power supply control board, and a connection member. The antenna board includes n patch antenna elements disposed at an interval P in an X direction where n represents a number equal to or greater than 2. The antenna board is disposed on the XY plane. The power supply control board has a thickness T. The power supply control board is disposed on an XZ plane. The connection member includes an insulating resin extending in the X direction and a joint electrode provided on a surface of the insulating resin. The connection member connects the antenna board and the power supply control board. The m antenna structures are each disposed in which the antenna board has a center line in the X direction that is located right or left alternately with respect to a center line of the power supply control board in the X direction.

**Related U.S. Application Data**

(63) Continuation of application No. PCT/JP2023/033555, filed on Sep. 14, 2023.

**Foreign Application Priority Data**

(30) Oct. 12, 2022 (JP) ..... 2022-164165

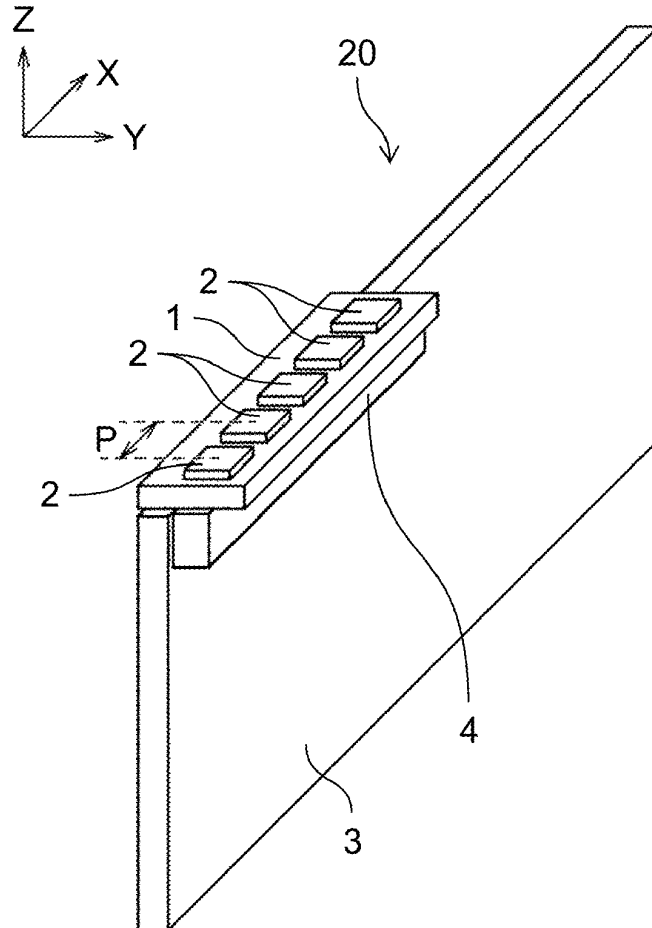



US 20250226883A1

(19) **United States**

(12) **Patent Application Publication** (10) **Pub. No.: US 2025/0226883 A1**  
**Khayatzadeh et al.** (43) **Pub. Date: Jul. 10, 2025**

(54) **ELECTRONIC DEVICE WITH RECIPROCAL ELECTRO-OPTICAL TRANSCEIVER**

(52) **U.S. Cl.**  
CPC ..... **H04B 10/112** (2013.01); **H04B 2210/006** (2013.01)

(71) Applicant: **Apple Inc.**, Cupertino, CA (US)

(57) **ABSTRACT**

(72) Inventors: **Ramin Khayatzadeh**, Munich (DE); **Bernhard Raaf**, Neuried (DE); **Josef Hausner**, Germering (DE)

An electronic device may include wireless circuitry with light sources that emit optical local oscillator (LO) signals onto optical paths coupled to a photomixer of an antenna. An electro-optical modulator (EOM) on an optical path may modulate one of the LO signals using an intermediate frequency signal and single sideband carrier suppression. The antenna may transmit and receive radio-frequency signals at the same frequency without adjustment to the LO signals. The frequency of the radio-frequency signals is equal to an offset between LO signals plus the frequency of the intermediate frequency signal. This may allow the device to switch between transmission and reception and/or frequencies of the radio-frequency signal without adjusting the phases of the light sources and optimizes wireless performance.

(21) Appl. No.: **19/012,645**

(22) Filed: **Jan. 7, 2025**

**Related U.S. Application Data**

(60) Provisional application No. 63/619,223, filed on Jan. 9, 2024.

**Publication Classification**

(51) **Int. Cl.**  
**H04B 10/112** (2013.01)

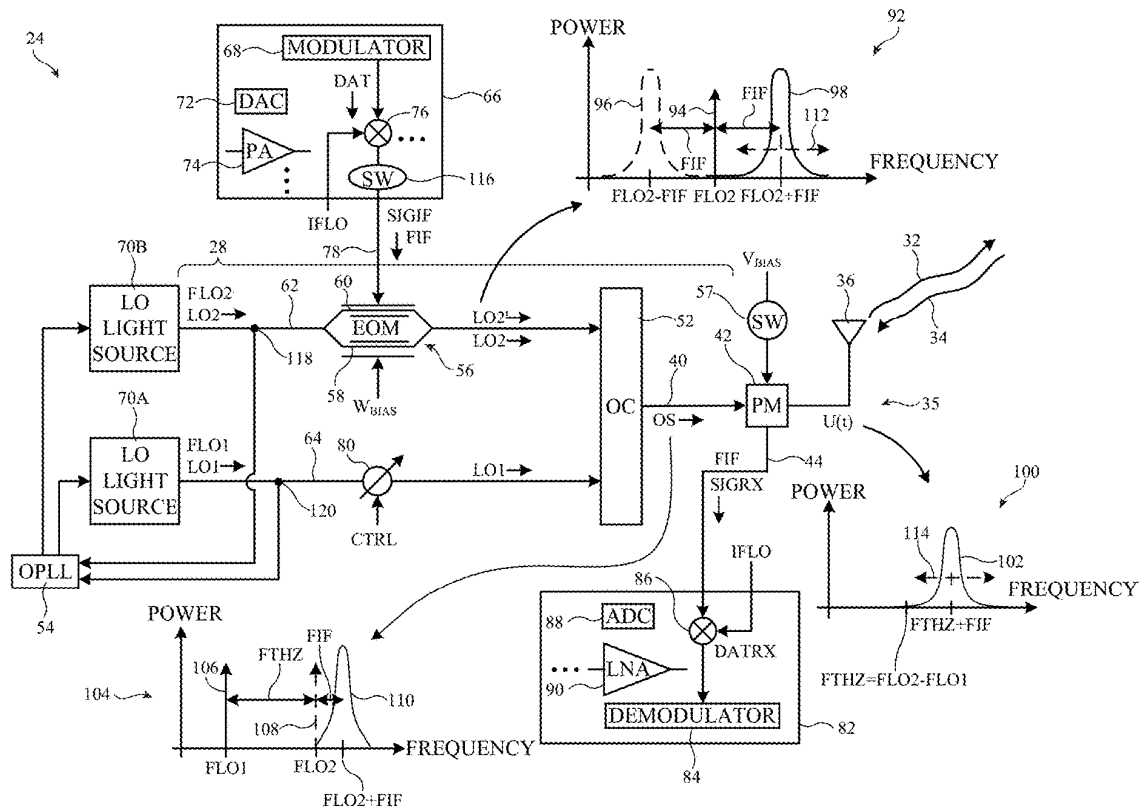



US 20250226962A1

(19) **United States**

(12) **Patent Application Publication**  
**Wang et al.**

(10) **Pub. No.: US 2025/0226962 A1**

(43) **Pub. Date: Jul. 10, 2025**

(54) **ANTENNA STRUCTURE AND ELECTRONIC DEVICE**

**Publication Classification**

(71) Applicant: **Huawei Technologies Co., Ltd.**,  
Shenzhen (CN)

(51) **Int. Cl.**  
**H04L 5/00** (2006.01)  
**H01Q 13/16** (2006.01)

(72) Inventors: **Hanyang Wang**, Reading (GB);  
**Chuanbo Shi**, Shanghai (CN); **Pengfei Wu**, Shanghai (CN)

(52) **U.S. Cl.**  
CPC ..... **H04L 5/0098** (2013.01); **H01Q 13/16**  
(2013.01)

(21) Appl. No.: **18/682,239**

(57) **ABSTRACT**

(22) PCT Filed: **Aug. 5, 2022**

According to embodiments, an antenna structure may include a first antenna element and a second antenna element. A first slot of the first antenna element and a second slot of the second antenna element extend in a first direction and are spaced apart in a second direction, and projections of the first slot and the second slot in the second direction at least partially overlap, where the second direction is perpendicular to the first direction. A first feed point of the first antenna element is disposed in a central region of the first slot, or disposed at an end of the first slot, and a second feed point of the second antenna element is disposed at an end of the second slot. An operating frequency band of the first antenna element is the same as or adjacent to an operating frequency band of the second antenna element.

(86) PCT No.: **PCT/CN2022/110435**

§ 371 (c)(1),

(2) Date: **Feb. 8, 2024**

(30) **Foreign Application Priority Data**

Aug. 12, 2021 (CN) ..... 202110922415.4

